

Алматы (7273)495-231
Ангарск (3955)60-70-56
Архангельск (8182)63-90-72
Астрахань (8512)99-46-04
Барнаул (3852)73-04-60
Белгород (4722)40-23-64
Благовещенск (4162)22-76-07
Брянск (4832)59-03-52
Владивосток (423)249-28-31
Владикавказ (8672)28-90-48
Владимир (4922)49-43-18
Волгоград (844)278-03-48
Вологда (8172)26-41-59
Воронеж (473)204-51-73
Екатеринбург (343)384-55-89
Иваново (4932)77-34-06
Ижевск (3412)26-03-58
Иркутск (395)279-98-46
Казань (843)206-01-48

Калининград (4012)72-03-81
Калуга (4842)92-23-67
Кемерово (3842)65-04-62
Киров (8332)68-02-04
Коломна (4966)23-41-49
Кострома (4942)77-07-48
Краснодар (861)203-40-90
Красноярск (391)204-63-61
Курск (4712)77-13-04
Курган (3522)50-90-47
Липецк (4742)52-20-81
Магнитогорск (3519)55-03-13
Москва (495)268-04-70
Мурманск (8152)59-64-93
Набережные Челны (8552)20-53-41
Нижний Новгород (831)429-08-12
Новокузнецк (3843)20-46-81
Ноябрьск (3496)41-32-12
Новосибирск (383)227-86-73

Омск (3812)21-46-40
Орел (4862)44-53-42
Оренбург (3532)37-68-04
Пенза (8412)22-31-16
Петрозаводск (8142)55-98-37
Псков (8112)59-10-37
Пермь (342)205-81-47
Ростов-на-Дону (863)308-18-15
Рязань (4912)46-61-64
Самара (846)206-03-16
Саранск (8342)22-96-24
Санкт-Петербург (812)-309-46-40
Саратов (845)249-38-78
Севастополь (8692)22-31-93
Симферополь (3652)67-13-56
Смоленск (4812)29-41-54
Сочи (862)225-72-31
Ставрополь (8652)20-65-13
Сургут (3462)77-98-35

Сыктывкар (8212)25-95-17
Тамбов (4752)50-40-97
Тверь (4822)63-31-35
Тольятти (8482)63-91-07
Томск (3822)98-41-53
Тула (4872)33-79-87
Тюмень (3452)66-21-18
Ульяновск (8422)24-23-59
Улан-Удэ (3012)59-97-51
Уфа (347)229-48-12
Хабаровск (4212)92-98-04
Чебоксары (8352)28-53-07
Челябинск (351)202-03-61
Череповец (8202)49-02-64
Чита (3022)38-34-83
Якутск (4112)23-90-97
Ярославль (4852)69-52-93

Россия +7(495)268-04-70

Казахстан +7(7172)727-132

Киргизия +996(312)96-26-47

Эл. почта: sao@nt-rt.ru || Сайт: <https://laser.nt-rt.ru>

FIBER
OPTICS



small components
MASSIVE IMPACT

Foreword

Dear Reader,

Fiber optic cables are becoming more and more important in industry, medical technology, data transmission, and sensor technology. As the demands placed on laser power, data volume, and data rates increase, so too do the demands on fibers, cables, and connectors.

The multitude of applications results in a large variety of optical cables with different fiber types and connectors.

LASER COMPONENTS offers a fiber optic assembly service that allows you to serve this market quickly. Take advantage of more than 25 years of experience in fiber optic cable assembly! We provide solutions that are optimally tailored to your applications and requirements. You benefit directly from our continuous process optimization. We respond directly to your feedback, which in turn allows you to keep your customers satisfied without exception.

We hope you enjoy browsing through this catalog. Our product engineers will be happy to answer any questions you may have.

Sincerely yours,



Patrick Paul
General Manager



Patrick Paul, General Manager

CONTENT

About us	008	Fibers with Shaped End Faces (Fiber Tips)	036
Individual Designs	008	Ball Lenses	037
Assemblies, Fibers, Cables, and Connectors	009	End Caps	037
Development	010	Fiber Optic Patch Cables for Networks	038
Complex Fiber Optic Developments	010	Single Mode / PM Cables	040
Development and Production Go Hand in Hand	010	Fibers with Metallization	041
Individual Project Planning	011	Lighting Assemblies (POF Fibers and Cables)	042
Assembling of Optical Fibers	012	Plastic Fibers for Lighting	042
Manufacturing in Germany	012	Side-Light POFs for Illumination	042
Our Strengths	013	POF Assemblies for Data Transmission	042
PM Production	013	Fiber Optic Sensor Assemblies	044
Production Facility	014	Assembled Fiber Bundles	044
Centricity Measurement	014	FBG Patch Cables	045
Laser Polishing	015	Fiber Optic Measuring Cables	046
End Face Coating	015	Reference Cables	046
Cleanroom	016	Launch Fibers	047
Markets	018	IR Fiber Cables / Hollow Silica Waveguide Assemblies ...	048
Fiber Assemblies	020	Patchcords for CO ₂ Lasers	048
High-Power Multimode Assemblies	024	Patchcords for Er:YAG Lasers	049
High-Power Patch Cables – Standard D80/SMA	024	Fiber Optic Connectors	050
High-Power Patch Cables – ModeStrip D80/SMA	026	Optical Fiber Options	052
Fibers with AR Coatings	028	Optical Large Core Fibers	054
Medical Assemblies	030	MM Fibers – Step Index	056
Invasive Fibers (Bare Fibers)	032	Broadband Optical Fibers	057
Acupuncture Fibers	033	UV Fibers	058
Data Cables for Medical Technology	034	UV-VIS Fibers	060
Custom Solutions for Medical Technology	035	VIS-NIR Fibers	061

MM Fibers – Gradient Index	062	Doped and Photosensitive Fibers	080
GI/MM Fibers for Extreme Environments.....	063	Photosensitive Fibers.....	080
Pure Silica GI/MM.....	064	Doped Fibers.....	081
Single Mode Fibers	066	Highly Germanium-Doped Fibers.....	081
VIS-NIR Single Mode Fibers.....	067	Erbium/Ytterbium-Doped Double-Clad Fibers.....	082
High-Temperature SM Fibers.....	068	IsoGain – Erbium-Doped Fibers.....	083
Dual-Band Carbon-Coated SM Fiber.....	068	Polarization-Maintaining Erbium-Doped Fibers.....	084
SM Fibers with a High-Temperature Acrylate Coating.....	069	Other Doped Fibers.....	085
SM Fibers with a Polyimide Coating.....	070	Spun Fibers	086
SM Fibers with a Quartz Core.....	071	Pump Fibers	088
Polarization-Maintaining (PM) Fibers	072	All-Silica Double-Clad Fibers.....	088
Standard PM Fibers.....	072	Passive Double-Clad Fibers with a Low Refractive Index... ..	089
Bow-Tie PM Fibers.....	072	Sapphire Fibers	090
Polarization-Maintaining Polyimide Fibers.....	073	Plastic/POF Fibers and Cables	092
PM Fibers – Telecommunications.....	074	POF Fibers.....	092
PM Gyro Fibers.....	075	POF Cables.....	093
PM Fibers with a Quartz Glass Core.....	076	Indoor and Outdoor LDF Multimode Cables	094
Bow-Tie Zing PM Fibers.....	077	Simplex Cables.....	095
Multicore Fibers	078	Duplex Cables.....	096
Standard Multicore Fibers.....	078	Breakout Cables.....	097
Fiber Optic Fan-Outs.....	079	Hollow-Core Fibers	098
		Fiber Coupling	100
		Fiber Collimators.....	102
		Fiber Coupling Systems.....	104
		Imprint	111

About us



Headquarters and Production facility, Olching/Munich

LASER COMPONENTS specializes in the manufacture and sale of optical and optoelectronic components. Since its founding in 1982, our family-owned company has grown steadily and expanded into new fields of business. Fiber assemblies have been manufactured at the company's headquarters in Olching near Munich since 1995. We also manufacture laser optics, laser modules, electronics, and photon counters at this location. In addition, LASER COMPONENTS Canada produces pulsed laser diodes. Moreover, the LASER COMPONENTS Detector Group, based in the U.S.A., is responsible for manufacturing avalanche photo-diodes and IR detectors.

In all product areas, an interdisciplinary development team works together with customers to find solutions to specific problems. Customers from all sectors benefit from our company's wide-ranging expertise and the close networking of the various locations.

Individual Designs

One of our strengths is custom manufacturing in product development: whether you wish to obtain individual pieces or large quantities, we accompany you throughout the entire production process – from the initial idea to the finished series.

Assemblies, Fibers, Cables, and Connectors

LASER COMPONENTS uses optical fibers to make cable assemblies and develops fiber optic components. In this catalog, we present both our manufacturing options and our standard products.



Development



Complex Fiber Optic Developments

Our company's headquarters in Olching is also the central headquarters of our R&D department at LASER COMPONENTS. In addition to fiber optic specialists with many years of scientific and practical experience, our motivated team consists of experts in optical thin-film technology and optoelectronics. Together, our team works cross-disciplinarily on projects aimed at the new and continued development of our products.

Development and Production Go Hand in Hand

The short communication pathways and channels of action between the R&D and production departments ensure optimum cooperation within the company. At numerous conferences, symposia, and trade fairs, our colleagues constantly keep up to date with the latest industrial and scientific developments. They use the knowledge acquired at these events for customized OEM projects and the development of new quality products.

Assembling of Optical Fibers



High Quality

We assemble all cables at our location in Olching near Munich. The advantages of manufacturing in Germany outweigh the challenges of remaining competitive in terms of price. We rely on the high professional competence of our employees and the guaranteed quality of our products. In addition, we are in charge of the incoming goods inspection of the components we receive and the outgoing goods inspection of the assembled cables we ship.



! Customer Specific Products

Ask for our individually designed products or use the cable configurator on our website!

</lc/assembly-selector>

Our Strengths

Our core competencies lie in the fields of power transmission and medical technology: from high-power fibers for diode lasers to sterile packed fibers for medical lasers and custom medical and industrial products. Thanks to extensive investments in technology and personnel, we also have the know-how to manufacture high-end applications in these demanding markets.

PM Production

The assembly of polarization-maintaining bow-tie and Panda fibers requires special knowledge and high precision. At LASER COMPONENTS, we also offer PM fiber assemblies according to your specific requirements.

Our Production Range

Types of Cables	Core Diameter										
	9 μm	50 μm	62.5 μm	100 μm	105 μm	200 μm	300 μm	400 μm	600 μm	800 μm	1000 μm
Standard Cables Data Transmission	■	■	■	■							
Cables for Sensor Technology					■	■	■	■			
Cables for Medical Technology						■	■	■	■		
High-Power Assemblies for Laser Industry					■	■	■	■	■	■	■
POF (Plastic Optical Fibers) for Sensor Technology, the Automotive Industry, and Design Illumination	different diameters										

Production Facility



Successfully competing on the market with state-of-the-art products requires state-of-the-art production facilities and precise testing equipment. In addition, qualified employees who know their equipment inside and out, but also bring in new ideas, are crucial. This results in very high-quality and innovative products.

Centricity Measurement

The high quality of the assembled cables is largely due to the alignment of the fiber core to the outer diameter of the ferrule. An increase in the power of the coupled laser light increases the centricity requirements. In the higher watt range, minimal deviations can cause the fiber to burn out, thus destroying it. With state-of-the-art measuring equipment, we are able to measure the eccentricity of the fiber to the outer diameter of the ferrule at a measurement tolerance of $\pm 0.5 \mu\text{m}$. Depending on the application, our customer can choose from eccentricity values of $< 20 \mu\text{m}$, $< 10 \mu\text{m}$, and $< 5 \mu\text{m}$.



Laser Polishing

The fiber ends are polished after assembly. The better the polish, the better the laser beam can be coupled into the fiber. The same, of course, applies to outcoupling and thus to the quality of the entire system. LASER COMPONENTS uses a precision process to achieve particularly low roughness depths. The result is fiber assemblies with maximum efficiency.

End Face Coating

In order to avoid back reflections, the fiber end faces often have to be coated with an anti-reflective layer (AR coating). LASER COMPONENTS benefits from its decades of experience in laser optic coatings. The fibers are processed in the same facilities as our precision optics. The coating materials are vapor-deposited in a plasma-assisted process that makes it possible to create particularly thin coatings. By applying these coatings, improvements in the coupling and outcoupling can be achieved to an even greater extent than with polishing. Depending on the coating and our customer's coupling conditions, an increase of up to 7 % is possible. The back reflections are minimized to a value of up to 0.1 %.

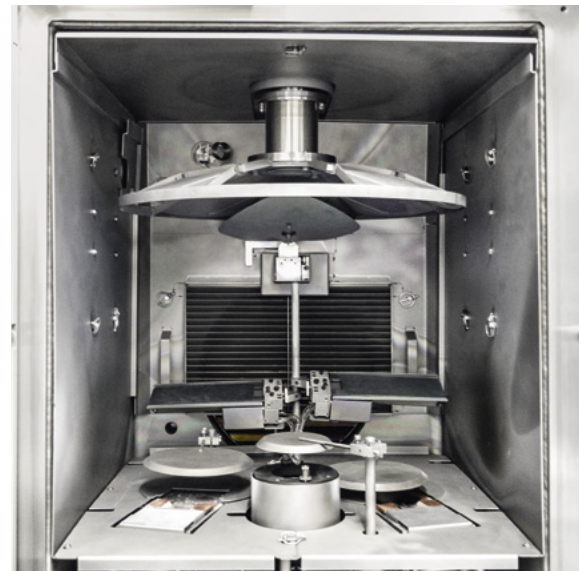

Production Facility



Cleanroom

LASER COMPONENTS develops and produces optical, optoelectronic, and fiber optic components for medical applications.

Our components are crucial for the quality and reliability of your products and solutions. That is why we work extremely carefully with a process-oriented quality management system, in which top quality has the highest priority and is the benchmark for customers, suppliers, and employees.

As a partner, we offer decisive advantages:

- Quality management system certified according to ISO 9001 and EN ISO 13485
- Complete range of services from development to final assembly
- Expertise in materials and processes
- All relevant production steps are validated and documented
- Electronic file management
- Traceability down to the smallest component is guaranteed
- All fiber optics for medical technology are manufactured under reproducible ISO class 7 and class 8 cleanroom conditions.
- Our product development and manufacturing teams work closely together to ensure optimum design, shorter development and manufacturing times, and faster delivery of your products.

Lichtwellen-
leiter
B.213
Reinraum



Markets

The use of fiber optic cables is no longer limited to data transmission. Optical fibers can now be found in a wide variety of industries and fields of application. The requirements for fibers, connectors, and protective sleeves are correspondingly diverse. But the technical possibilities have also been developed further: in many cases today special fibers are available that meet the requirements of a specific application exactly.

High-Power Fibers / Photonics / Laser Industry

LASER COMPONENTS has been manufacturing special assemblies for demanding customers in photonics for many years. Here the technology has been optimized for the transmission of high powers – mostly via the use of step index multimode fibers. The quality of the assemblies often depends on details in manufacturing technology. Decades of experience and comprehensive know-how have made us a top supplier in the industry. Mechanical engineering companies and manufacturers of pump lasers, diode lasers, and complex laser systems rely on our quality and on technologies such as ModeStrip, special connector designs, and adhesive technology.

Medicine and Biosciences

LASER COMPONENTS meets the high demands of the medical industry with its cleanroom production of fiber optic assemblies. In most cases, existing technologies are customized. Our product range includes in-situ fibers, delivery fibers, and data cables for operating rooms and conditions. The fields of application are also versatile and range from urology, dermatology, dentistry, ophthalmology, and laser acupuncture to analytical methods such as MRT and OCT. This also includes spectroscopy and imaging methods, etc. in biology and chemistry.



Telecommunications and Data Transmission

Data transmission is a widely known market for optical fibers. As the amount of data increases, so too do the requirements placed on transmission networks. The type of fiber used depends not only on the amount of data but also on the transmission path. For short distances – for example in building cabling or automobiles – low-cost POF cables can also be used instead of optical fibers. Both gradient index multimode and single mode fibers are used for transmission networks.

Lighting

In addition to medical lighting solutions with biocompatible, sterilizable glass fibers, optical fibers are mainly used for design lighting – for example in saunas, luminous textiles, and starry skies in luxury cars. As a rule, this is carried out with plastic fibers that have a high numerical aperture and diffuse radiation characteristics. Since the fibers do not require polishing or other elaborate processing, most of these designs can be implemented very inexpensively.

Sensors

Fiber optic sensor technology is an important growth market. With this technology, changes in the scattering characteristics of light are measured and conclusions drawn about unusual stresses. As these sensor systems function over long distances and without electricity, they are mainly used under demanding environmental conditions – for example to monitor pipelines and rail lines, but also in substations where electrical sensors do not function due to the electromagnetic fields present. Special fibers with complex core structures (bow-tie, Panda, etc.) are required for these applications.

Fiber Assemblies



Good to Know

Contact us personally with your individualized request or use our "cable configurator" on our website:

</lc/assembly-selector>



Detailed information is available on our datasheets.
Visit our website!

Cable Assemblies

We quickly and reliably supply fiber optic assemblies from our in-house production facilities. Our product range includes cables for data transmission, medical technology, and high-power transmission, as well as fiber bundles for lighting and cold light sources.

Product Overview

We assemble all-silica low-OH, high-OH, and special fibers with all standard connector types:

- SMA – with and without a free-standing fiber
- FC
- DIN
- D80 (compatible with LD-80, Mitsubishi) with a free-standing fiber
- ... and many more

For information on differentiating between low-OH and high-OH fibers, see page 054.

Fibers and Jackets

The fiber core consists of pure silica and is available in diameters between 200µm and 940µm. We are happy to provide you with information on other core diameters upon request.

Select any of the following protective jackets to avoid damage to the fiber:

- Teflon jacket – available in different colors
- Flexible metal jacket – available in different colors upon request
- PVC jackets – available in different colors

Coated End Faces to Increase Input and Output Coupling Efficiency

Furthermore, we can equip fiber end faces with an anti-reflection (AR) coating to minimize back reflections during coupling and outcoupling.

Measurement Logs

Upon request, we can provide measurement protocols for the fiber assemblies ordered:

- Measurement protocol for attenuation
- Measured values for eccentricity
- Photos of end faces

Quality Assurance

Each individual fiber cable is checked using a high-precision measuring microscope during outgoing goods inspection.

High-Power Multimode Assemblies

We have been specializing in the assembly of fibers for the transmission of high laser power since 1995. Through controlled cleanroom conditions we can guarantee high cleanliness of the fiber end face.

The laser polishing of fibers that we developed in house is another one of our special features at LASER COMPONENTS. This considerably increases the efficiency of coupling power into the fiber.

Possible Applications

High-performance patch cables are mainly used for laser power transmission, but they are also used in medical technology and for pumping crystals.

Technology

Heat is generated when transmitting high power. For this reason, we manufacture patch cables for such applications from high-quality optical fibers and a connector with a free-standing fiber.

To ensure that the assemblies can withstand the temperatures, adhesives are not used in the front part of the connector. The break-resistant, free-standing fiber is surrounded by air and mounted evenly with the front face of the connector. We use copper ferrules for better heat dissipation.

The maximum couplable power depends on the coupling conditions; please contact our office for more information.



High-Power Patch Cables – Standard D80/SMA

Assembled fiber optic patch cables with a free-standing fiber and SMA or D80 connectors.

Patch Cables with SMA Connectors

SMA fiber assemblies are particularly used in pump fibers for diode lasers. One important quality feature is the low eccentricity of the fiber core to the outer diameter of the ferrule. The standard specification is $< 10\mu\text{m}$. We also manufacture assemblies with an eccentricity of $< 5\mu\text{m}$ upon request.

D80 Fiber Assemblies

D80 laser assemblies are mostly used as connecting fibers for diode laser systems. The eccentricity is normally less than $10\mu\text{m}$. Upon request, however, we can also guarantee an eccentricity of less than $5\mu\text{m}$ by measuring all fibers with precision microscopes during outgoing goods inspection.

For D80 assemblies, we can also apply AR coatings to the fiber end face upon request.

Pump Fibers. What Are They?

High-power multimode assemblies are also used as pump fibers. Diode-pumped solid-state lasers are more efficient than their lamp-pumped counterparts. Laser diodes in the wavelength range between 808 nm and 980 nm are used for pumping. Pump fibers focus the pump energy on the laser rod.



Specifications High-Power Patch Cables Standard D80/SMA

	D80	SMA
Fiber Diameter [μm]	100–1500 μm in step index fibers with an NA of 0.22 and 0.12 (upon request); low-OH and high-OH	100–1500 μm in step index fibers with an NA of 0.22 and 0.12 (upon request); low-OH and high-OH
Cladding	<ul style="list-style-type: none"> ▪ Metal jacket with PVC coating (outer diameter: 5.6 mm in black and red) ▪ Stainless steel jacket (outer diameter: 4.0 mm and 4.6 mm) 	
Attenuation [dB]	< 1.5 (selected fibers available upon request)	
Fiber Length [m]	1 – 15	
Eccentricity [μm]	< 5 (on request), < 10 or < 20	
Connector	D80 connector (LD80 compatible) with and without a counter pin	SMA905, which is free standing and has a hexagonal union nut
Ferrule Material	Copper	ARCAP or Copper
Laser Power [W]	10–300 (depending on the fiber diameter)	
Heat Sink	Version for passive air cooling. Heat sink available upon request with water supply	
Label	Individual marking of the heat sink is possible (e.g., with a company logo); each fiber is equipped with laser-marked heat shrink tubing, which contains our lot number (can also be provided with custom data upon request)	

High-Power Patch Cables – ModeStrip D80/SMA

ModeStrip assemblies ensure high optical beam quality without cladding modes in order to avoid thermal hotspots in the fiber cladding and transmit maximum power.

Assembled Cables with ModeStrip Connectors

In ModeStrip assemblies, undesired modes are extrapolated from the fiber cladding. This offers several advantages:

- High optical beam quality without cladding modes
- No thermal hotspots in the fiber cladding
- No destruction of the fiber cable during high-power transmission

ModeStrip patch cables are specifically assembled according to customer requirements. Precise controls in the outgoing goods department guarantee an eccentricity of $< 10\mu\text{m}$ – and if desired, $< 5\mu\text{m}$ as well. We can equip the fiber end face with an AR coating on an optional basis. Upon request, we can also provide you with measurement reports with the attenuation and centricity values, as well as photos of the end faces.

Why ModeStrip?

Theoretically, the light in optical fibers is reflected several times without loss at the interface between the fiber core and the fiber cladding according to the principle of total reflection. In practice, however, small amounts of power can be released into the fiber cladding. At 2–3 % in the case of high-power transmission, this can lead to the destruction of the fiber cable. ModeStrip connectors provide a remedy by stripping the cladding modes and dissipating the resulting heat in a controlled manner via a cooling element. This prevents the thermal destruction of the fiber connector and simultaneously improves the beam profile at the fiber exit.



Specifications High-Power Patch Cables ModeStrip D80/SMA

	D80	SMA
Fiber Diameter [μm]	100–1500 μm in step index fibers with an NA of 0.22 and 0.12 (upon request); low-OH and high-OH	100–1500 μm in step index fibers with an NA of 0.22 and 0.12 (upon request); low-OH and high-OH
Cladding	<ul style="list-style-type: none"> ▪ Metal protection jacket with green PVC cladding (outer diameter: 8.3 mm) ▪ Metal protection jacket with black PVC cladding (outer diameter: 5.6 mm) ▪ Metal protection jacket with red PVC cladding (outer diameter: 5.6 mm) ▪ Stainless steel jacket (outer diameter: 4.0 mm or 4.6 mm) ▪ Other claddings available upon request 	<ul style="list-style-type: none"> ▪ Metal jacket with PVC coating (outer diameter: 5.6 mm in black and red) ▪ Stainless steel jacket (outer diameter: 4.0 mm or 4.6 mm) ▪ PTFE jackets (outer diameter: 2.1 mm; free choice of color)
Attenuation [dB]	< 1.5 dB (selected fibers available upon request)	
Fiber Length [m]	1 – 10	1 – 15
Excentricity [μm]	< 5 (upon request) and < 10	
Connector	D80 connector (LD80 compatible) with and without a counter pin	SMA905, which is free standing and has a hexagonal union nut
Ferrule Material	Copper	
Laser Power [W]	100–200 (depending on the fiber diameter)	
Heat Sink	Version for passive air cooling (Heat sink available upon request with water supply)	
Label	Individual marking of the heat sink (e.g., with a company logo) is possible; each fiber is equipped with laser-marked heat shrink tubing, which contains our lot number (can also be provided with custom data upon request)	

Fibers with AR Coatings

Assembled fibers with coated end faces: for higher coupling efficiency, the anti-reflection (AR) coating minimizes disruptive back reflections.

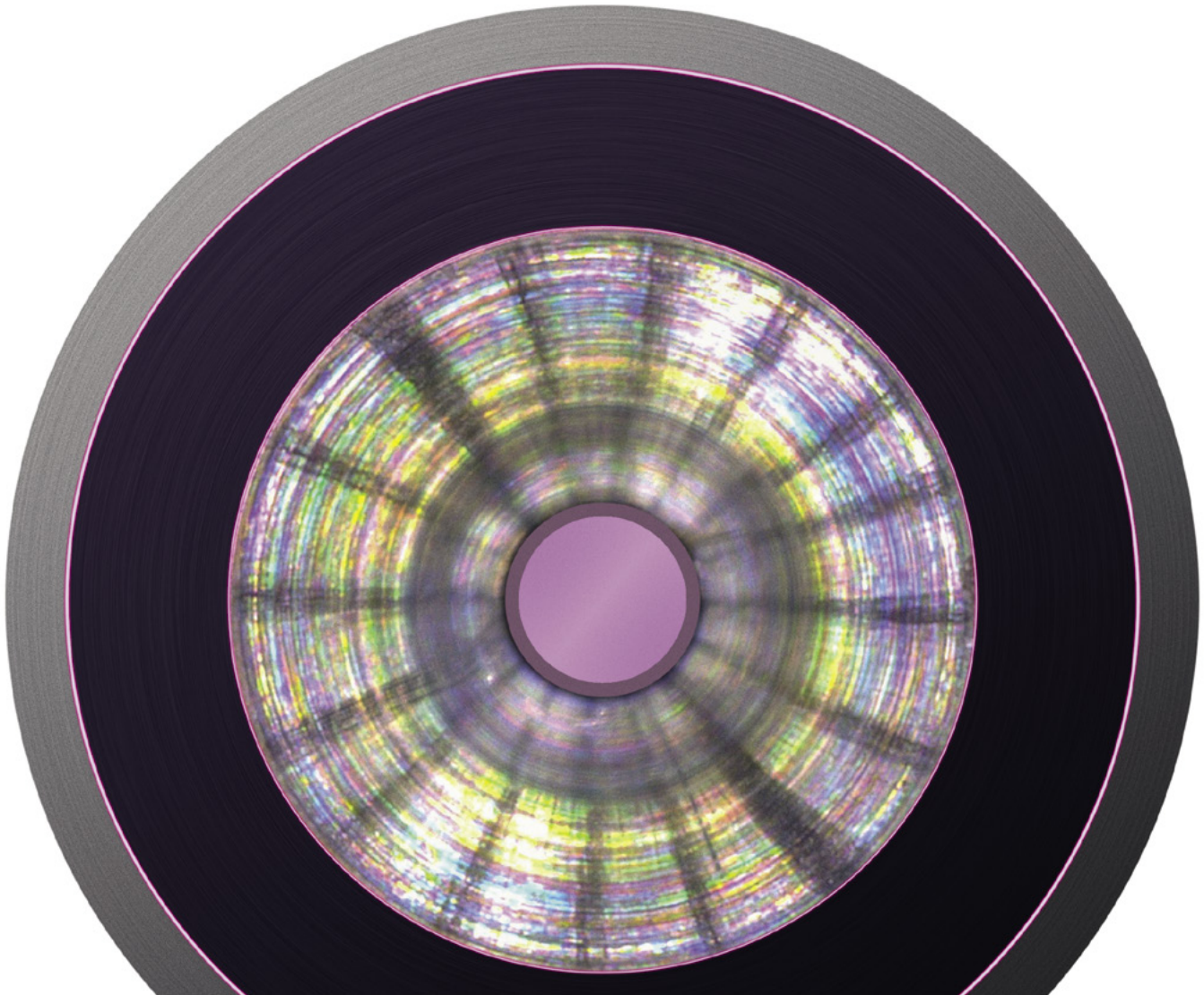

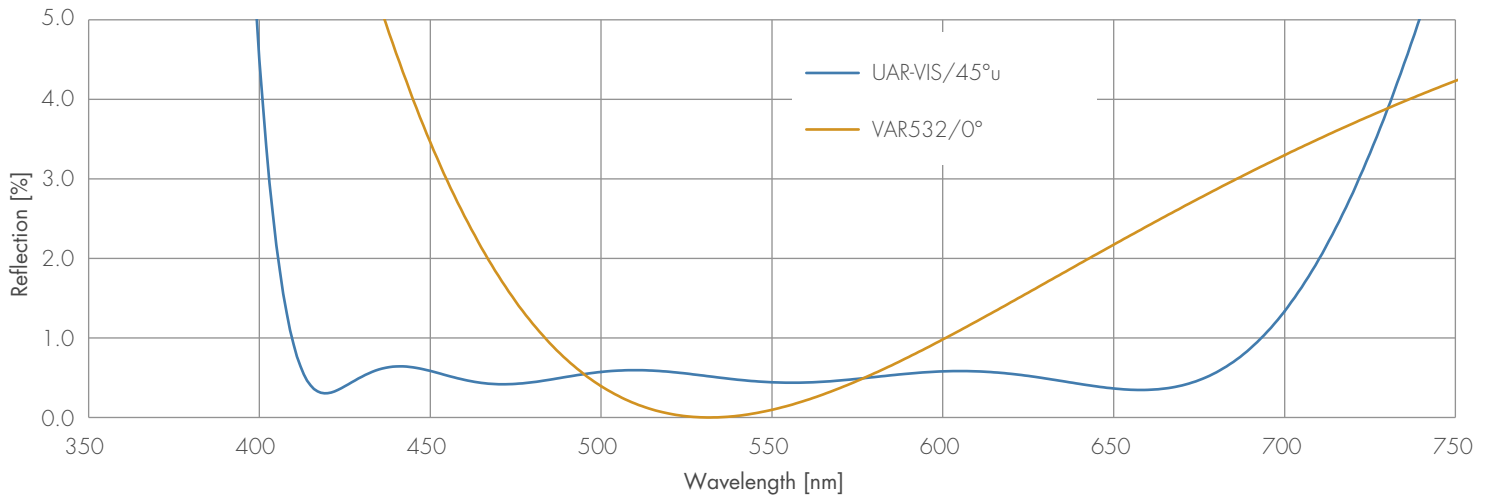

Fiber Optics with an Anti-Reflection Coating

At every glass-air interface, back reflections occur which amount to about 4 % of the incident light. To avoid this, the fiber ends are coated with AR coatings. We offer anti-reflection coatings for various central wavelengths, such as 532nm, 808 nm, 980nm, 1064nm, 1310nm, 1480nm, and 1550nm.

The coatings are available as single AR (anti-reflective coatings for one wavelength), dual AR (anti-reflective coatings for two wavelengths), and broadband AR (anti-reflective coatings for a wide wavelength range).

In principle, all fiber types can be equipped with an AR coating. It is only important that all materials used are suitable for a high vacuum, do not evaporate, and can withstand the thermal stress of a coating.

Coated fiber optic cables are mainly required for power transmission, medical technology, and material processing.

Assembly and coating are carried out directly by LASER COMPONENTS. Custom surface specifications are possible.

! AR Coating Possible

- **Coating:** Single AR, Dual AR, Broadband AR
- **Central Wavelength:** 532–1550nm
Other wavelengths on demand.
- **Reflection:** $R = 0.1 - 0.5\%$

Medical Assemblies

Medical Technology

In medical technology, fibers are often used for lighting or in transmitting high laser power.

In these cases, they serve as delivery fibers for various laser systems (e.g., for tattoo and hair removal, prostate treatment, kidney stone fragmentation, and varicose vein sclerotherapy).

We offer fibers for the transmission of wavelengths between 300nm and 2500nm.

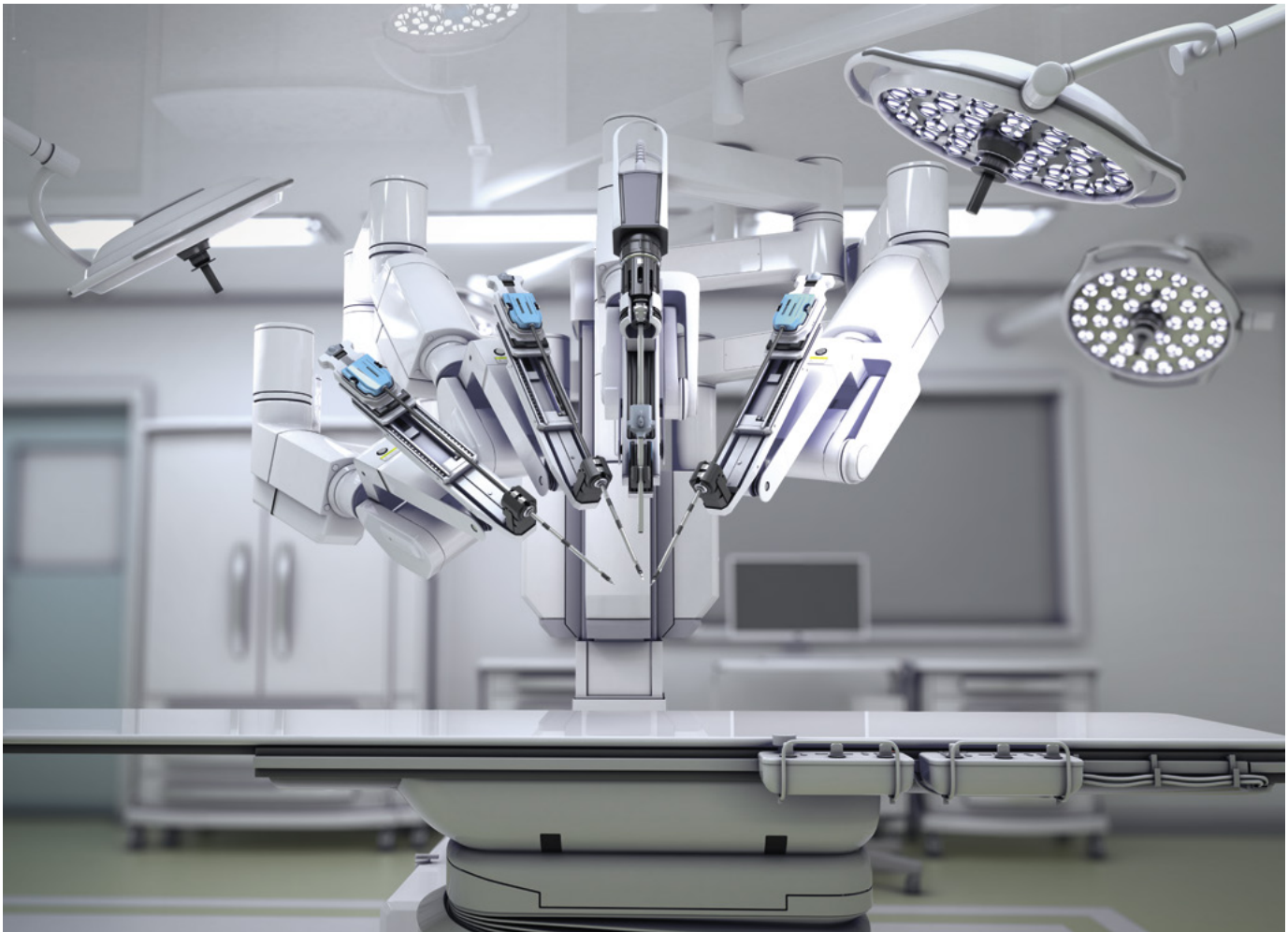

Specifications

- **Fiber:** Step index fiber
- **Core diameter:** 200–1000 μm
- **Connectors:**
SMA, free-standing SMA; custom connectors can be used upon request
- **Standard lengths:** 1–10 m
- **Cladding:** PTEE, silicone, bare fiber with Tefzel jacket
- **Optional:** Sterile packaging
- **Accessories:** Sterilizable MediStrip fiber stripper



Invasive Fibers (Bare Fibers)

Invasive fibers are fibers that are used in the body for medical purposes.

Depending on the application, they can be manufactured in a wide variety. As a rule, they are bare fiber pigtailed that are equipped with an SMA connector on one side. The second side is typically cleaved or equipped with so-called fiber tips such as, for example, a spherical lens.

Upon request, we can also supply such fibers that are coded, for example, with an RFID tag.

Typical applications include kidney stone fragmentation, respiratory medicine, and tissue ablation.



Specifications Invasive Fibers (Bare Fibers)

Fiber Diameter [µm]	200 / 272 / 365 / 400 / 550 / 600 / 800
Connector	SMA 905 Standard or according to customer specifications; SMA free-standing
Fiber Length [m]	1 – 10
Sterilizable	Yes
Fiber Material	Biocompatible (not for entire assembly)
Ferrule Material	ARCAP
End Faces	Polished, Cleave, Ball lens
Label	On demand: individual labeling on shrink tube

Acupuncture Fibers

Optical fibers for laser acupuncture.

Laser acupuncture is an alternative procedure to conventional acupuncture with needles. Trigger points are irradiated with laser radiation at clearly defined wavelengths and power.

The acupuncture tips, i.e. the optical waveguides used in this treatment, are specifically manufactured to meet customer requirements under cleanroom conditions. The fiber diameter and fiber type can be selected individually.

Numerous designs are available for the acupuncture handpiece. If you wish, we can also develop an individualized solution for you.



Specifications Acupuncture Fibers

Fiber Type	Quartz fiber (biocompatible) or POF
Fiber Diameter [μm]	200 / 400 / 500 / 600
Buffer	Silicate-cladding
Connector	SMA905 / Acupuncture sleeve
Fiber Length [m]	1 – 10
Ferrule Material	ARCAP
Label	On demand: individual labeling on shrink tube

Data Cables for Medical Technology

Optical fibers for data transmission in operating rooms – Manufacturing according to customer requirements.

Fiber Optic Cables for the OR

Data cables are also needed in the medical sector. Fiber optic cables are increasingly being used for this purpose. Particularly when used in operating rooms, the highest hygiene requirements apply. For these applications we manufacture our products in class 7 to class 8 cleanrooms in order to ensure the hygiene requirements for the subsequent reprocessing of medical products.

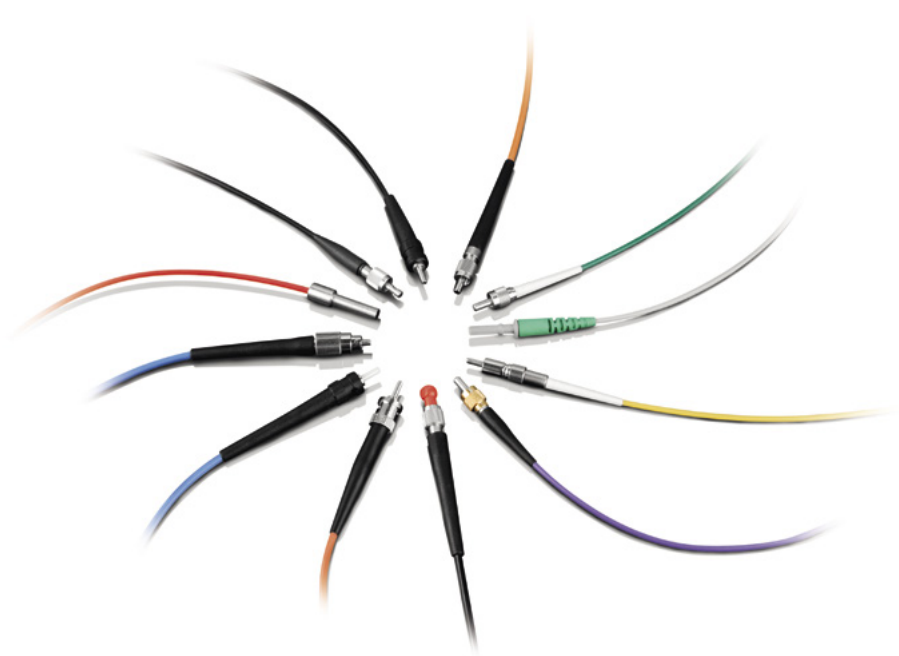

QM System
certified
according to
ISO 9001 and
EN ISO 13485

Specifications Data Cables for Medical Technology

Fiber Type	Single mode; Gradient index GI50 and GI62.5; HCS 200µm
Buffer	SZ-, PU-, PE-tube or according to customer specifications
Connector	SMA905, ST, SC, FC, LC, E-2000, V-PIN, F07 or according to customer specifications
Length	According to customer specifications

Custom Solutions for Medical Technology

For illumination and treatment: optical glass fibers for medical technology

Custom Fiber Assemblies for Medical Technology

Quality is always our focus at LASER COMPONENTS. We work closely with our customers to implement customized validation and quality assurance systems.

Manufacturing and Quality Management

We unite all facilities and capacities under one roof for the development and production of custom solutions in medical technology. With our process-oriented quality management system and cleanroom production, we offer a development and production team specialized in custom fiber optics solutions – from special fiber optic assemblies to optical components.

The trend toward miniaturization does not stop at medical technology either: complex optical lens systems are increasingly being replaced by space-saving fiber optic solutions.

Fiber-based optical coherence tomography (OCT) solutions are already being developed and manufactured today, as are medical probes for examinations and operations, special laser acupuncture solutions and metal-free on/off switches.

As a partner, we offer crucial advantages:

- Quality management system certified according to ISO 9001 and EN ISO 13485
- Complete range of services from development to final assembly
- Expertise in materials and processes
- All relevant production steps are validated and documented
- Electronic file management
- Traceability down to the smallest component is guaranteed.
- All fiber optics for medical technology are manufactured under reproducible ISO class 7 and class 8 cleanroom conditions.
- Our product development and manufacturing teams work together to ensure optimum design, efficient production processes, and faster delivery.



Fibers with Shaped End Faces (Fiber Tips)

The properties and characteristics of fiber end faces can be modified using a special manufacturing process. The result is so-called shaped fibers.

Find our core products on the following page.

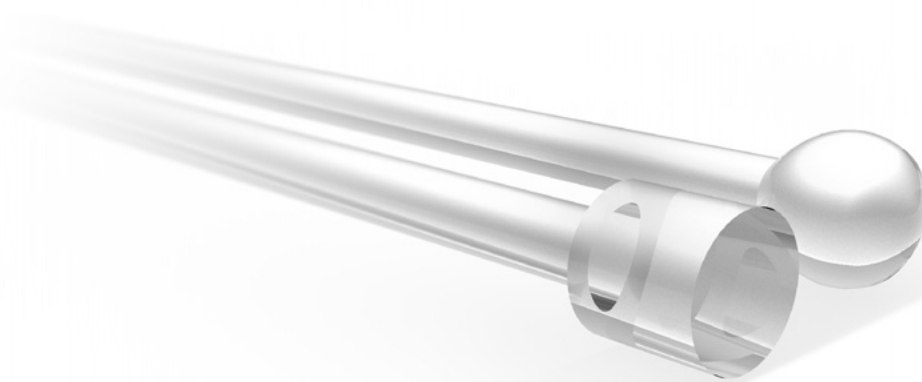

Ball Lenses

Ball lenses drawn from the fiber optimize the radiation characteristics. Depending on the application, they focus or collimate coupled light.

Such fibers are mainly used in medical technology. The rounding of the fiber has another positive effect: it reduces the risk of injury in medical applications.

The focal length of the lens element depends on the diameter of the sphere. This can amount to a maximum of 2.5 times the diameter of the fiber, making it possible to achieve a focal length of several hundred μm .

Specifications

- **Fiber core diameter:**
200 μm , 365 μm , 400 μm , 550 μm ,
600 μm (more available upon request)
- **Ellipticity:** > 0.9
- **Wavelength range:** 190–1900 nm
- **Numerical aperture of the fiber's raw material:** 0.22
- **Connectors (opposite end):** Standard SMA905, free-standing SMA905 with copper and ARCAP ferrules, ST, FC
- **Buffer:** Bare fiber, PVC, PEEK, PTFE, and silicone
- **Temperature range:** -65 °C to 140 °C

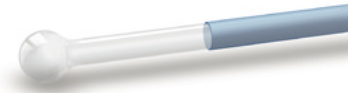

Ball lens

End Caps

Fiber optic end caps are rod lenses made of quartz glass that are fused to the fiber. They are also available with an AR coating upon request.

In the case of fiber end faces with end caps, the power density is distributed across a larger area. This increases the damage threshold of the laser fiber, and the laser power can be more easily coupled into the fiber. Particularly fibers with a small core diameter can be used for high-power applications because significantly higher powers can be coupled into the fiber.

Specifications

- **Fiber diameter:** 100 μm , 200 μm ,
400 μm , 600 μm , 800 μm , 1000 μm
(special fibers available upon request)
- **End cap diameter:**
0.1–2.5 mm (quartz glass)
- **End cap length:** 0.6 mm to several mm
- **Numerical aperture of the fiber's raw material:** 0.22
- **Connection options:** Free-standing SMA with copper and ARCAP ferrules, D80 connectors with a copper ferrule
- **Buffer:** Bare fiber, PVC, PTFE, and metal
- **Temperature range:** -65 °C to 140 °C



End cap

Fiber Optic Patch Cables for Networks

Fiber optics have become an integral part of today's communication infrastructure: in mobile communication, wide area and city networks, LANs, corporate networks, and data centers.

Our international partners manufacture cost-effective fiber optic connecting cables, patch cables, and couplings. Thus, we can offer you an entire range of high-quality patch cables for single mode and multi-mode applications (OM1–OM5 fibers).

For small quantities and fast delivery, we also rely on our German production facilities for standard assemblies. Depending on your requirements, we combine the cost effectiveness of our worldwide production sites with fast delivery from Germany.



Identifier	Type	Cable Type	Fiber Type	Connector 1	Connector 2	Length	Cable Type	Special Specifications
OPV-		Simplex		FC/APC	FC/APC	In meters	3/2 mm cable	0.1 dB connector
		Duplex		FC/UPC	FC/UPC		900 μm	Reference cable
		Ribbon cable (MPO)		LC/PC	LC/PC		Bare fiber	Others
Patch	Patch cable			LC/APC	LC/APC		Special cables	
Pig	Pigtail			E2000/APC	E2000/APC			
Fan-out		SM	Single mode	SC /PC	SC /PC			
Adapter [coupling]		OM1	Multimode	SC/APC	SC/APC			
		OM2	Multimode	MU	MU			
		OM3	Multimode	MPO	MPO			
		OM4	Multimode	MTP	MTP			
		OM5	Multimode	Others	Others			
		PM & Wavelength	Polarization-maintaining					
		Others						

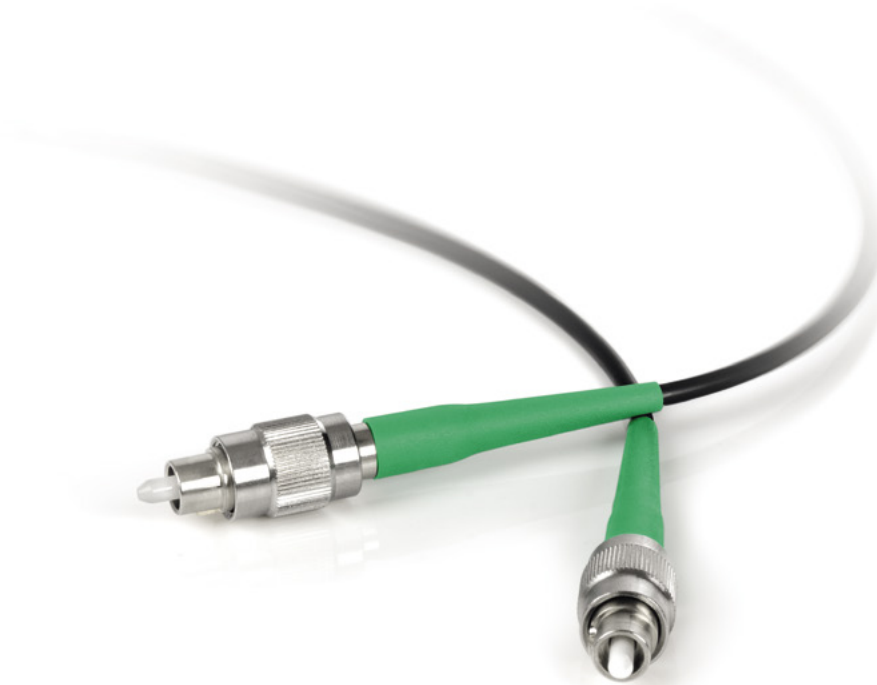

Single Mode / PM Cables

For patch cables and special custom cables, LASER COMPONENTS has an entire range of standard connectors and connector combinations. The following types are available in both straight (physical contact (PC)) and angled (angled physical contact (APC)) versions: FC, SC, E2000, LC and MU. All combinations and lengths are possible. Use the cable configurator on our website to send us your inquiry.

Small custom series are developed and manufactured in Germany. Standard assemblies are manufactured efficiently in larger quantities.

Polarization-maintaining fibers are also connected in Germany as PM assemblies. In this case, the main connector is usually an FC or FC/APC. Other types are also available upon request.

The extinction ratio between the polarization directions places different demands on the assemblies: in this respect, both passive and active alignment (1550nm) is possible.



General Specifications Fiber Optic Patch Cables (Single Mode)

	PC	APC
Max. Input Attenuation [dB]	≤ 0.3	≤ 0.3
	0.1 (Connector on request)	
Typ. Input Attenuation [dB]	0.2	0.2
RL/Return Loss [dB]	≥ 55	≥ 65
Temperature Range [°C]	40–80	

Fibers with Metallization

The production of metallized fibers is complex. For example, they can be hermetically connected to housings and other structures by soldering. They are also used in high-temperature applications.

The metallization process takes place in special coating systems. Larger quantities are simultaneously coated with metal layers. This process is therefore not attractive pricewise for single pieces. Contact our product specialists for further information.



Lighting Assemblies (POF Fibers and Cables)

Optical Fibers for Illumination

Various solutions are available for lighting. High quality is provided by glass fibers, which are used, for example, in medical lighting and can be sterilized.

Polymer optical fibers (POFs) can be produced cost effectively but have a significantly higher attenuation than glass fibers. Therefore, they are particularly suitable for light transmission across short distances of up to 20 m. They are not only used for signal transmission but also for innovative design lighting.

Plastic Fibers for Lighting

POFs can be used, for example, to create sauna lighting, luminous textiles, and starry skies in luxury cars. In addition to price, "good" illumination is also important. This requires a high numerical aperture and diffuse radiation characteristics. Special polishes do not need to be used for fiber optic lighting. This is why we can offer these POFs at particularly favorable prices – as bare fibers or as a cable version, depending on your requirements.

Side-Light POFs for Illumination

Side-light POFs are very special polymer optical fibers that emit coupled light laterally across the entire length of the fiber. In standard optical fibers – so-called "end-light fibers" – the coupled light is transmitted within the fiber and only coupled out at the end face. In this case, the lateral light extraction should be as low as possible.

For side-light POFs, very special fibers are therefore required, in which targeted interference in the core-cladding interface leads to lateral radiation. Individual side-light fibers achieve good illumination properties up to a length of 4 m. Fiber bundles should be used for more challenging length and illumination requirements.

POF Assemblies for Data Transmission

For signal transmission across short distances (e.g., within rooms or equipment), POF cables are a cost-effective alternative to fiber optics. A high degree of polish is required to ensure that transmission is as loss-free as possible. We offer different polishing grades to suit your application. The lower the polishing requirements, the cheaper the patch cable.

These versatile POF fibers can be assembled with almost all cables and connectors.

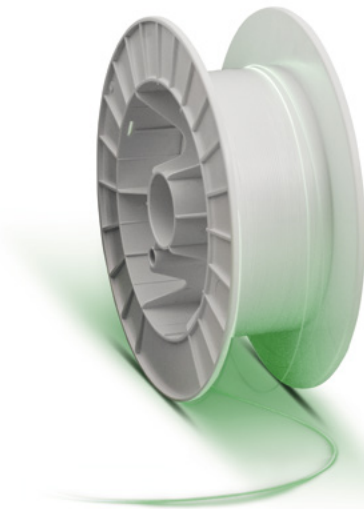

Specifications

- **Fiber:** Polymer optical fiber (POF)
- **Fiber core diameter:** 250–3000 μm
- **Connectors:**
ST, SMA, FC, SC, V-PIN, F05, F07
Custom connectors can be used upon request.
- **Standard lengths:** 1–50 m
- **Cable versions:** Indoor and outdoor
- **Cladding:** PVC, PTEE, metal, silicone
- **Cable design:** Simplex, duplex, zipcord, fiber bundle

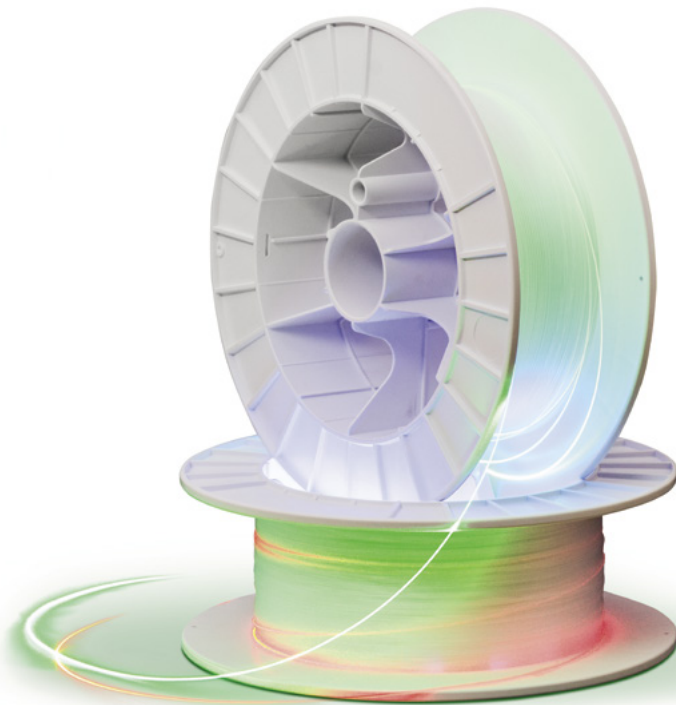

Good to Know

Side-light POF fibers for design illumination!

Give us a call!

Fiber Optic Sensor Assemblies

Both assembled glass fibers and inexpensive alternatives with polymer optical fibers (POFs) are used in sensor technology. While POFs are only used for light and data transmission across short distances,

glass fiber bundles can be used to implement complex sensor systems (e.g., in temperature measurement, gas measurement systems, and the turbidity measurement of liquids).

We develop complex fiber optic sensor assemblies together with our customers.

Assembled Fiber Bundles

Fiber bundles split or combine beams. For this purpose, fibers consisting of independent strands are combined with a branching device in a single cable.

In addition to pure illumination solutions, they are also used in numerous other areas such as material processing, UV curing, photolithography, UV spectroscopy, sensor technology, analytics, UV illumination, and Raman spectroscopy.

OEM Manufacturing

Since fiber bundles are usually custom solutions, we offer a large variety of different types.

All standard fibers are available in different diameters. In combination with standard connectors, special ferrules, and fiber arrays, they can be processed into fiber bundles in prototype and series quantities.

The number of fibers within a fiber bundle can reach up to several hundred. Thus, there is no limit to the active area and cross-section.

High-Power Fiber Bundles

New technologies make it possible to manufacture so-called fused fiber bundles for high-power applications. These fiber bundles are fused such that the adhesive, which could be destroyed by the high power, is not found in the front surface area or unnecessary dead zones. This has led to damage to fibers and connectors in the past. Now, it is possible to transmit power that is equivalent to the damage threshold of the fiber material used – generally 1 GW/cm^2 . Fused fiber bundles thus qualify for use in high-power lasers, lamp transmissions, and high-temperature applications.



FBG Patch Cables

In FBG pigtails, a Fiber Bragg Grating (FBG) is integrated into the fiber core to filter certain wavelengths.

FBG fibers are used in fiber optic measurement technology (e.g., for temperature, pressure, sound, and strain measurements, as well as sensor multiplexing). In data transmission, FBGs are components of wavelength division multiplexing (WDM) systems.

Fibers with UV FBGs

FBGs are inscribed with UV light on a standard basis. The fiber core must first be stripped of its coating. Following the inscription process, a new coating is applied with a recoater. The major advantage of this standard method is that the FBGs can be designed particularly flexibly in the wavelength spectrum. They are, therefore, used in demanding sensor and telecommunications applications.

Femtosecond Method

FBGs inscribed with a femtosecond laser are embedded into the fiber without the need to remove the coating. Since a recoating is, therefore, not required, the fiber maintains its high mechanical stability. In addition, the gratings can also be inscribed in non-photosensitive material (e.g., in pure silica fibers, in which the attenuation effects of hydrogen, radiation, and UV are significantly lower).

Femtosecond FBGs, therefore, offer considerable advantages under harsh environmental conditions and are in demand wherever the fiber is subjected to high mechanical stress. They can be found, for example, in the oil and gas industry and in nuclear power plants.

Fiber Optic Measuring Cables

Fiber optic reference cables and launch fibers are used to ensure the best possible coupling conditions when referencing and making measurements via an OTDR, when making fiber optic measurements

via an attenuation measuring device, and when monitoring the dead zones of the first connector during OTDR measurements. The measuring accuracy depends largely on the quality of these cables.

Our measuring cables are equipped with a master connector and a coupling connector on a standard basis.

Fiber Optic Reference Cables

Reference Cables

Reference cables are used for the measurement of assembled fiber optic cables and connectors from our standard production line.

Reference Cables Including Test Report

Our reference cables contain interferometrically tested master connectors (reference connectors).

In comparison to connectors manufactured by us, these master connectors must meet significantly higher quality criteria. Their optical properties meet the requirements of the EN 50377-X-Y standard. They have very low values for insertion loss, fiber core eccentricity, and pole offset. Reference cables are manufactured in a special process and require a great deal of know-how and experience.

Our range of reference cables is large and offers a variety of versions and combinations with master connectors and standard connectors. Reference cables are offered in cable lengths of three meters. They are available as SM and MM versions.

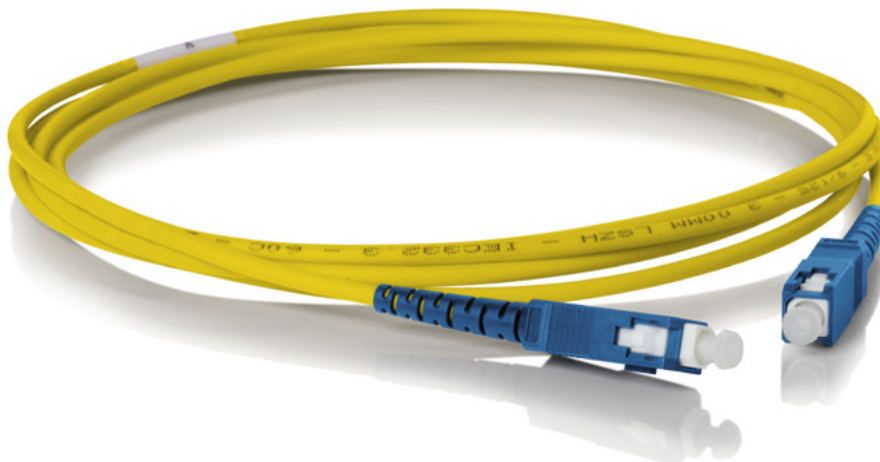

Launch Fibers

Launch Fibers for Optical Measurements

Launch fibers are necessary for all OTDR measurements and are mandatory for acceptance measurements. They also make it possible to evaluate the first connector in the link and reduce dead zones. The same applies to receive fibers for evaluating the last connector in the link.

Launch and Receive Fibers

In multimode fibers, the launch fibers make it so that the measuring conditions (i.e., the coupling conditions into the fiber to be measured) are always identical. If an additional receive fiber is used, the last connector can also be evaluated. The fiber type should always match the fiber to be measured; otherwise, measurement errors may occur.

Product Range

All standard connector combinations are possible. We offer different designs (e.g., small fiber rings and plastic cases). In addition, the patch cables can be equipped with a special protective jacket or made to be self-stretching.

The minimum length of the launch fiber depends essentially on the pulse width used at the OTDR. Usually, 1000m fibers are used in the single mode range and 100m fibers in the multimode environment.



IR Fiber Cables / Hollow Silica Waveguide Assemblies

IR Fiber Optics

Infrared wavelengths cannot be transmitted via conventional fibers with a quartz glass core because the coupled light is absorbed by the material.

For power transmission in industry and medicine, special fibers are used for CO₂ and Er:YAG lasers (10.6 μm and 2.94 μm, respectively).

Patchcords for CO₂ Lasers

The heart of the patchcord for CO₂ lasers is a hollow-core fiber with a core diameter of 500 μm, 750 μm, or 1000 μm. The fiber is usually protected with a metal jacket. The fiber material itself is biocompatible and can be sterilized for medical applications.

So-called SMA905 connectors are used as the main connection. These connectors are widely used in laser applications. Alternatively, we also offer assemblies with FC or ST connectors.

Pilot Beam Transmission

With our CO₂ fibers it is possible to simultaneously transmit a pilot beam to make the exact point of impact of IR radiation visible. You can find fiber coupling solutions on page 100.

Specifications Patchcords for CO₂ Laser

Fiber Diameter [μm]	500 / 750 / 1000
Buffer	PVC, PTFE, bare fiber or metall cladding
Fiber Length [m]	1 – 6
Connector	SMA, ST, FC
Laser Power [W]	≤ 65 cw
RFID	On request
Biocompatible	Yes
Sterilizable	Yes

Patchcords for Er:YAG Lasers

Er:YAG lasers are mainly used in dermatology, dentistry, and other special applications.

For the power transmission of Er:YAG lasers, patchcords are used which are optimized for the wavelength 2940 nm in order to virtually eliminate power losses. The biocompatible fibers can be sterilized and offer all the prerequisites for medical applications.

Inquire about our patchcord assemblies and specify among other things:

- Fiber type: Hollow-core or sapphire fiber
- Fiber diameter of the optical fiber
- Connector

Hollow-Core Fibers

Hollow-core fibers for Er:YAG lasers are equipped with a silver mirror coating on the inside, followed by a silver iodide coating. This creates an efficient dielectric IR reflector that can be optimized for certain wavelength ranges between 3 μm and 20 μm .

Sapphire Fibers

Sapphire fibers are special fibers grown from a crystal. They are characterized by the excellent material properties of a sapphire crystal. Thus, they are chemically almost neutral, and their melting point is particularly high at above 2000 °C. At the same time, they are as flexible as a glass fiber.

Specifications Hollow-Core Fiber Er:YAG-Laser

Fiber Diameter [μm]	500 / 750 / 1000
Buffer	PVC, PTFE, bare fiber or metall cladding
Fiber Length [m]	1–6
Connector	SMA, ST, FC
Laser Power [W]	$\leq 65 \text{ cw}$
RFID	On request
Biocompatible	Yes
Sterilizable	Yes

Specifications Sapphire Fiber Er:YAG-Laser

Fiber Diameter [μm]	100 / 150 / 250 / 325 / 425
Buffer	PVC, PTFE, bare fiber or metall cladding
Fiber Length [m]	1–2
Connector	SMA, ST, FC
Biocompatible	No
Sterilizable	No

Fiber Optic Connectors

Connector Types

In the world of fibers, the variety of connector types is at least as high as the number of fiber types and core diameters. A wide range of fibers with core diameters ranging from 50 μm to 1500 μm are used especially in sensor and measurement technology. In order to be able to use them correctly, the appropriate connectors are required.

At LASER COMPONENTS, we provide you with the appropriate connector for your fiber diameter. There are different drilling dimensions available for all standard connector systems such as FC, SMA, ST, Toslink, V-PIN, and D80. We equip your cables with the desired connector types. Of course, we can also have ferrules and sleeves manufactured according to your requirements.

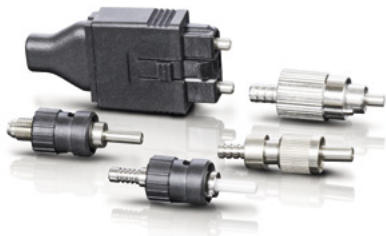

FC Connector Systems

FC connectors are widely used in the U.S.A. and Asia, where they are mainly used in telecommunications networks.

They are equipped with an axially spring-loaded pin to limit the contact force of the end face and enable physical contact between two end faces. The connector is locked with a thread. Its ferrule has a diameter of 2.5 mm.

As a rule, the connector – with its anti-twist protection – is used for single mode applications. Multimode versions are also available.



FC



SMA

SMA Connector Systems

SMA connectors are mainly used for multimode fibers and POFs with large core diameters. They are robust, easy to assemble, and widely diverse.

The ferrules of SMA connectors have an outer diameter of 3.175 mm and are available in a variety of materials (e.g., ARCAP and copper, which ensures good heat dissipation even at high power levels). SMA connectors are locked with knurled or hexagon nuts.

In addition to our classic shape, which is fixed by gluing and polishing, LASER COMPONENTS also offers both crimp & cleave (C&C) and reusable quick-assembly connectors. Our product range also includes free-standing SMA connectors for medical technology and the coupling of high power. The fiber end face is free standing in the connector, which prevents the transmission of power to the adhesive. Our ModeStrip version specifically removes the cladding modes from the fiber and thus ensures optimum beam quality even at high optical laser power.

ST Connector Systems

ST connectors are easily recognized by their typical bayonet lock, with which they can be locked rather quickly. Thus, they are often referred to as bayonet fiber optic connectors (BFOC). The outer diameter of the ferrule is 2.5 mm.

ST connector systems are primarily used in telecommunications networks and applications with large core fibers.

Toslink Connector Systems

FO5 and FO7 connectors are also known as Toslink connectors. They were originally developed for the digital transmission of audio signals. Typical applications include optical networks, industrial electronics, and consumer electronics. Toslink connectors meet the Japanese industrial standard (JIS).

These connectors are used exclusively for SI 200/230 μ m and 1 mm plastic fibers. The diameter of the ferrule is 2.5 mm.

V-PIN Connector Systems

“Versatile link” and V-PIN connectors are widely used in fiber optic technology. These easy-to-mount connectors are mainly used in conjunction with POFs and HCS 200/230 μ m fibers for data transmission, but they are also available for 1 mm plastic fibers. The outer diameter of the ferrule is 3.8 mm. Assemblies with V-PIN connectors can be used for indoor and outdoor applications.

D80

D80 connectors are used for coupling high power where heat dissipation plays a crucial role. The assemblies are therefore equipped with copper ferrules with good conductivity and a heat sink. ModeStrip versions are available on an optional basis. The connectors are fully compatible with Mitsubishi LD-80 connectors and are available with or without a twist lug. The outer diameter of the ferrule is 4.0 mm.



ST

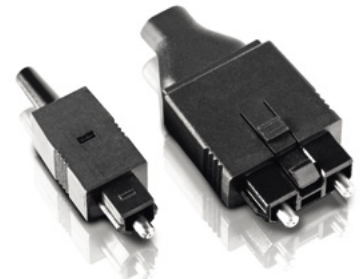

Toslink



D80



V-PIN

Optical Fiber Options



+46 31 703 7173

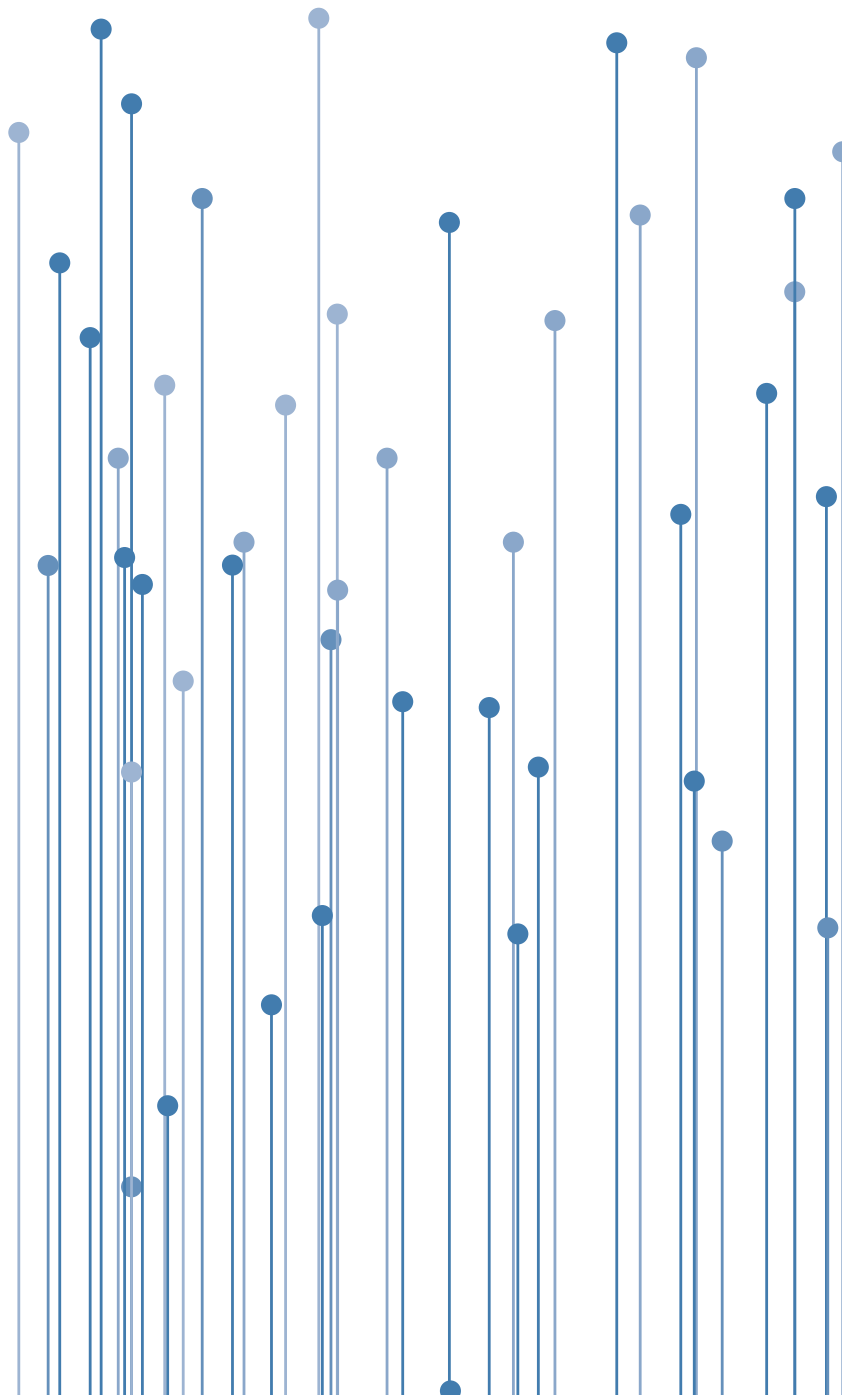

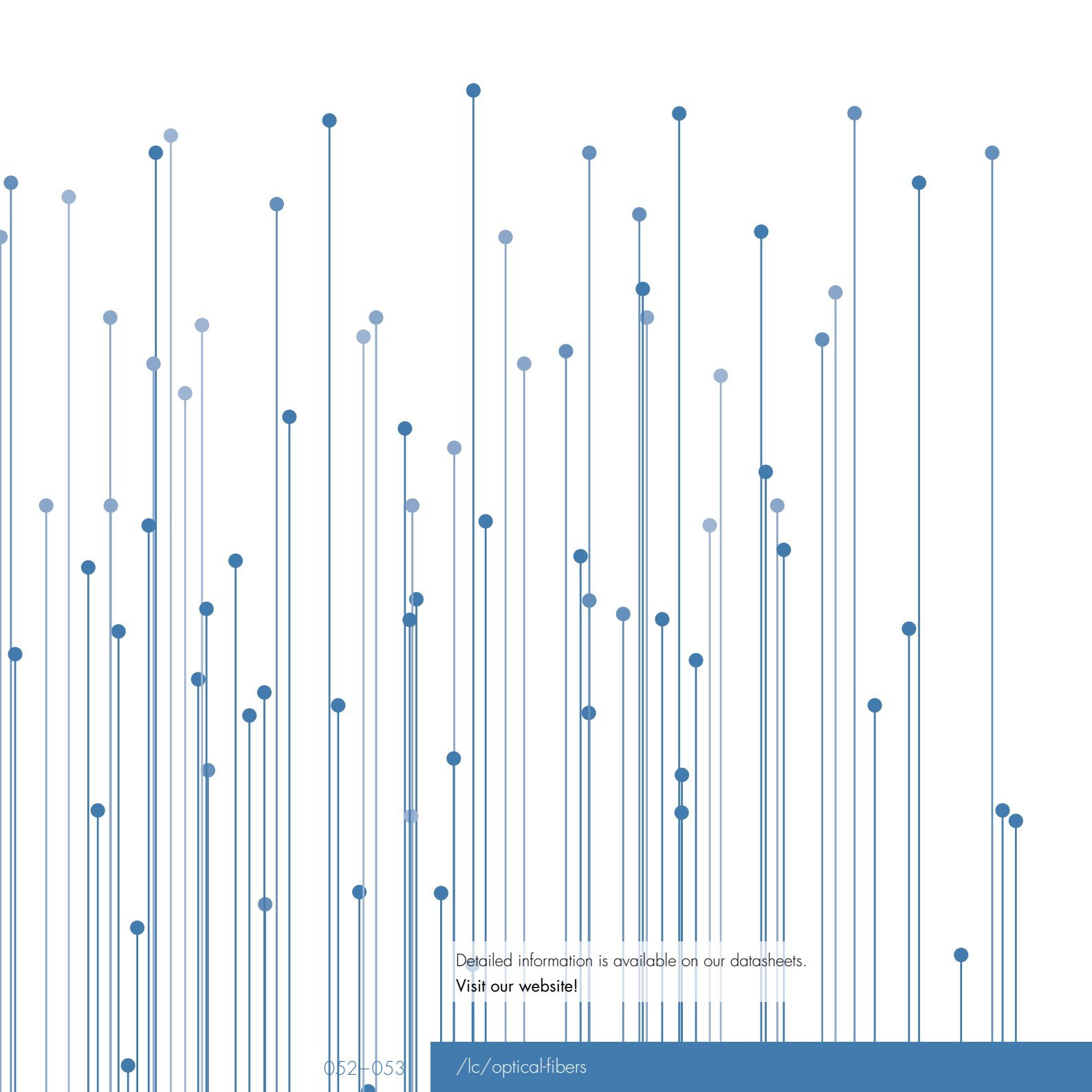

Detailed information is available on our datasheets.
Visit our website!

052-053

/lc/opticalfibers

Optical Fibers

We Focus on Quality.

For our fiber assemblies, we exclusively use high-quality optical fibers from leading manufacturers with many years of experience in key fields such as analytics, medicine, aviation, military, industry, telecommunications, and industrial communication. In addition to standard fibers and complete solutions that are ready for immediate use, we also offer a wide range of large core, SM, PM, MM, photosensitive, doped, multicore, spun, and pump fibers, as well as FBGs, for your assemblies.

Upon request, we can also process individual solutions with fibers that have been specifically manufactured to meet your requirements.

Product Range

On the following pages, we provide you with an overview of individual fiber types and their specific properties. We assemble the fibers selected by you with various connectors according to your specifications (see fiber optic connectors on page 050).

Standard Fibers

- **High-temperature fibers** (pages 056, 058–061, 064, 068–071, 073)
- **Large core glass fibers with a step index profile:**
Core diameter: 50–2000 μm
Applications: Data transmission, power transmission, medical technology, sensor technology (page 056)
- **Broad-spectrum fibers** cover a large wavelength range from 275 nm to 2100 nm (page 057)
- **Deep UV fibers** with good long-term properties at wavelengths of < 200 nm (page 058)
- **High-OH fibers:** Fibers with a high OH content for wavelengths in the UV to VIS range (page 060)
- **Low-OH fibers:** Fibers with a low OH content for wavelengths in the VIS to NIR range (page 061)
- **Glass fibers with a gradient index profile:** Core/cladding diameter: 50/125 μm , 62.5/125 μm , 100/140 μm
Applications: Data transmission, sensor technology (page 062)
- **Single mode fibers** (page 066)
- **Polarization-maintaining fibers (bow-tie and Panda)** (page 072)
- **Multicore fibers with matching fan-outs** (pages 078, 079)
- **Photosensitive fibers** (page 080)
- **Spun fibers** (page 086)
- **Sapphire fibers with a step index profile:** Core diameter: 250–425 μm
Applications: Spectroscopy, medical technology, sensor technology (page 090)
- **Plastic fibers with a step index profile:** Core diameter: 250–3000 μm
Applications: Lighting, sensor technology (page 092)
- **Hollow-core fibers with a step index profile:**
Core diameter: 500–1000 μm
Applications: Medical technology, power transmission of CO₂ and Er:YAG wavelengths (page 098)

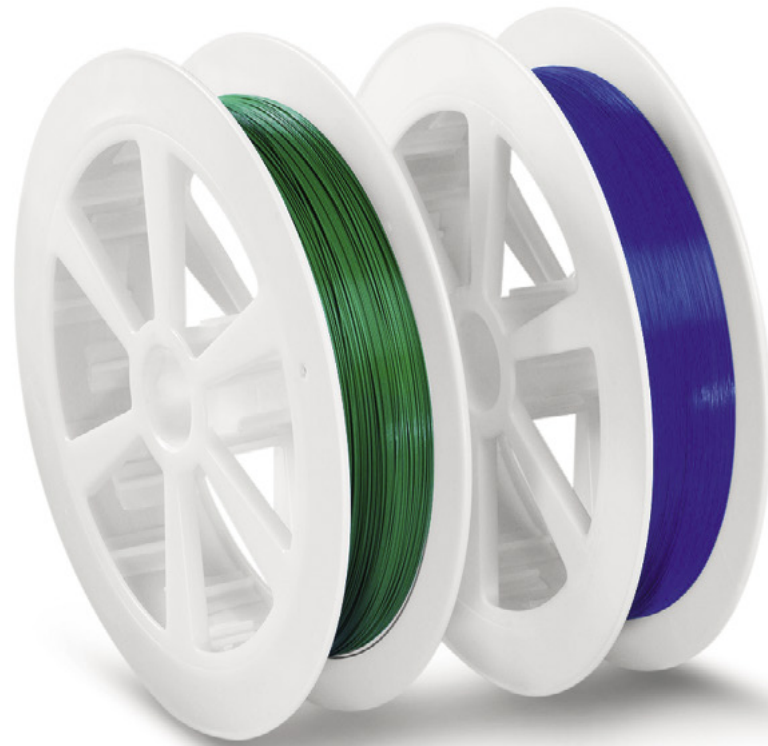

MM Fibers – Step Index

Step index fibers are used for the transmission of laser power in sensor technology, industrial applications, and medical technology.

Step index fibers are divided into launch and large core fibers.

Launch Fibers

So-called launch fibers have a numerical aperture (NA) of 0.15 to 0.22 and are available in core diameters of 40–105 μm .

Large Core Fibers

Large core fibers have core diameters from 200 μm to 2000 μm and are available with different numerical apertures (0.22; 0.37; 0.48; 0.66). The light can easily be coupled into the fiber with low-cost diodes.

These fibers can be processed with inexpensive assembly techniques and are particularly suitable for the transmission of high powers.

Large core fibers have a limited bandwidth. This is relevant if coherent signals must be transmitted across long distances.

Features

- Step index (SI) fibers get their name from the step-shaped refractive index profile between the fiber core and cladding. The refractive indices in the core and cladding are constant. The refractive index of the core glass is always higher.
- Depending on the wavelength range, differently doped fibers are used: low-OH fibers for the near infrared range and high-OH fibers for UV rays.

Broadband Optical Fibers

Broadband fibers are a special feature of our product portfolio. They are ideally suited for spectroscopy applications in which a very wide wavelength spectrum is transmitted.

This fiber type combines the NIR transmission properties of a low-OH fiber with the UV stability of a high-OH fiber. Depending on the solarization properties, the fiber types can be distinguished between FBP (without solarization resistance) and FBPI (with very good solarization properties).

FBP Broadband Fiber Silica/Silica*

Core Diameter [μm]	50–600
Coating Material	Polyimide
Number of Layers	3
Numerical Aperture	0.22

FBPI Broadband Silica/Silica with UV-Grade*

Core Diameter [μm]	200–600
Coating Material	Polyimide
Number of Layers	3
Numerical Aperture	0.22

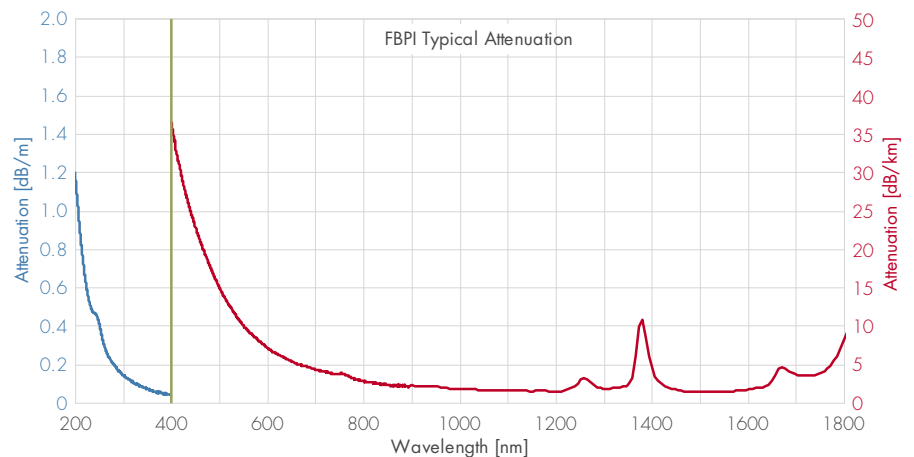
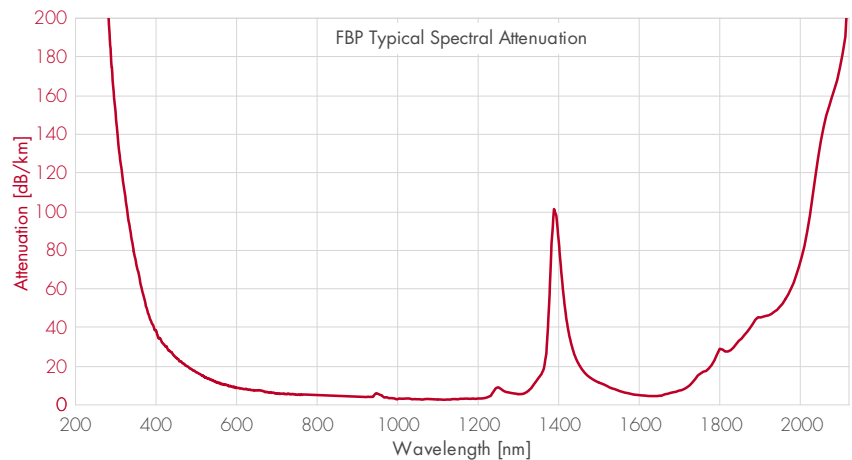

* Detailed datasheets on each type of fiber can be found on our website or on request. Many of the fibers featured on this page are also available as industrial cables.

UV Fibers

Low-cost UV LEDs and UV lasers such as the excimer laser are increasingly replacing classic deuterium and xenon lamps. This also makes the use of glass fibers for UV transmission interesting. They are used, among other things, for spectroscopic investigations of ions and atoms, but interesting possibilities are also opening up in analytics. Another field of application includes laser medicine, for example in dermatology and ophthalmology.

Selecting a Suitable Fiber

When selecting a fiber for your application, it is important to carefully compare the performance characteristics and price of the following four fiber types. If, for example, you only use wavelengths from 250 nm to the visible range, standard low-cost FVP fibers would be well suited. For applications with strict stability requirements in the deep UV range that only require a short lifespan, the FVP-UMVI fiber would be an appropriate choice. For applications that require stability and a long lifespan in the deep UV range, the FDP fiber is the best choice.

In order to make correct fiber selection for a UV application, three main criteria must be observed:

1. Initial Attenuation

The initial attenuation is the attenuation of a new fiber before any UV radiation is exposed. It depends on the wavelength and is typically given in dB/km.

2. Additional Attenuation by UV Irradiation

The additional attenuation caused by UV radiation is usually referred to as solarization. The greatest impairment occurs at wavelengths below 250 nm. The damage is particularly large at around 214 nm. The magnitude of this additional loss largely depends on the type of fiber.

3. Stability After UV Irradiation

If the initial UV irradiation is suspended in a fiber, some of the initial solarization damage will regress after a few hours. The condition of the fiber achieved after regeneration is then permanently maintained. This property is useful if maximum transmission rate is a priority.

The following quartz fibers can be used for UV transmission:

- **FVP fiber:** This standard high-OH fiber for the transmission of visible light has a relatively low attenuation even in the UV spectrum.
- **FVP UVM fiber:** In this inexpensive standard UV fiber, the core of a high-OH fiber has been modified to exhibit improved properties when used with UV light.
- **FVP UMVI fiber:** This hydrogen-enriched fiber does not exhibit virtually any deterioration when used with UV light. However, this advantage is achieved at the expense of lifetime because after a short time, the fiber loses its hydrogen enrichment and becomes an FVP UVM fiber again. By cooling or using a large core diameter, the lifetime can be considerably extended.
- **FDP fiber:** The solarization-resistant FDP fiber is optimized for use in the deep UV range (190 nm). Even without cooling, this fiber does not exhibit lifetime restrictions.

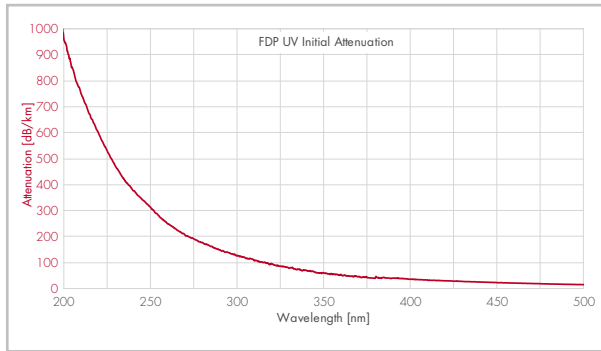

Typical Attenuation of FDP Series

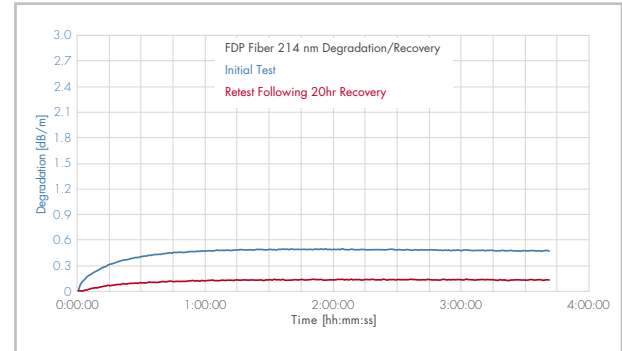

FDP Fiber 214 nm Degradation and Recovery

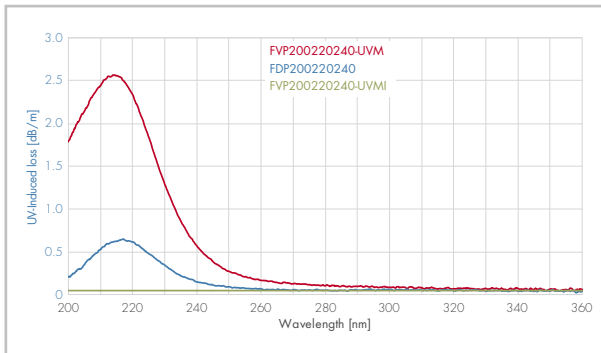

Comparison FVP Fiber and FDP Fiber

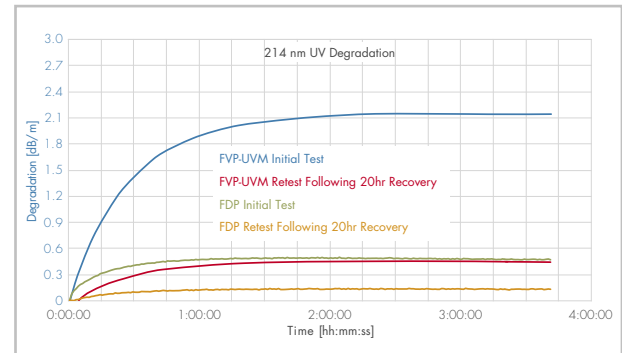

FDP Fiber 214 nm UV Degradation

Available Fiber Diameters [μm]

FVP	50–1000
FVP-UVM	50–1000
FVP-UVM1	50–1000
FDP	100–600

UV-VIS Fibers

UV-VIS fibers can be found, for example, in data transmission, sensor technology, lighting, and power transmission. As a rule, these are standard high-OH fibers.

The fiber core always consists of fused silica that has been enriched with OH. It is surrounded by a coating made of silica or hard cladding materials. Depending on the coating material, the numerical aperture is 0.22 (silica) or 0.37 (hard cladding). The entire fiber is protected from mechanical influences by a layer of materials such as Tefzel, acrylate, polyimide, and nylon. In applications with high power transmission, a second coating layer is usually added: an additional low-index coating with a numerical aperture of 0.37, which guarantees reliable power transmission even with strong bends. In addition, these fibers are also suitable for guiding cladding modes in small quantities.

Detailed datasheets for individual fiber types can be found on our website or requested from us. Many of the fibers described here are also available as industrial cables.

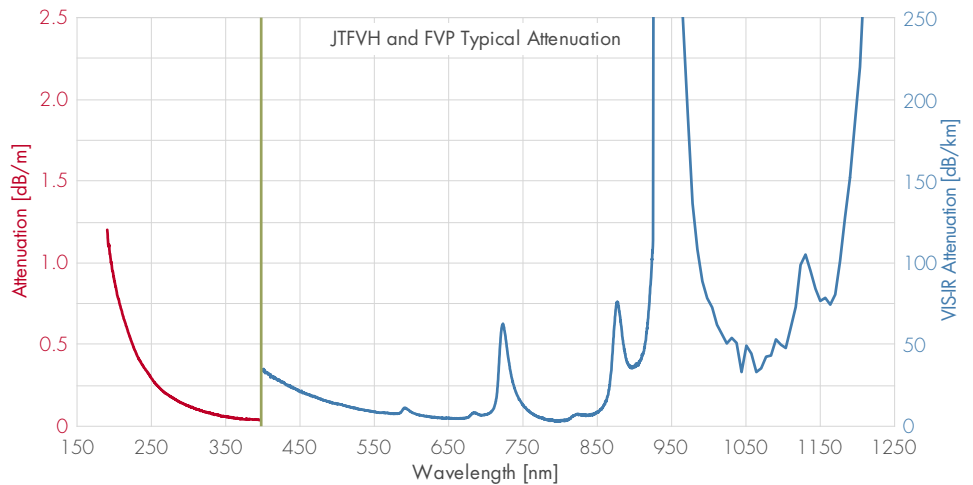
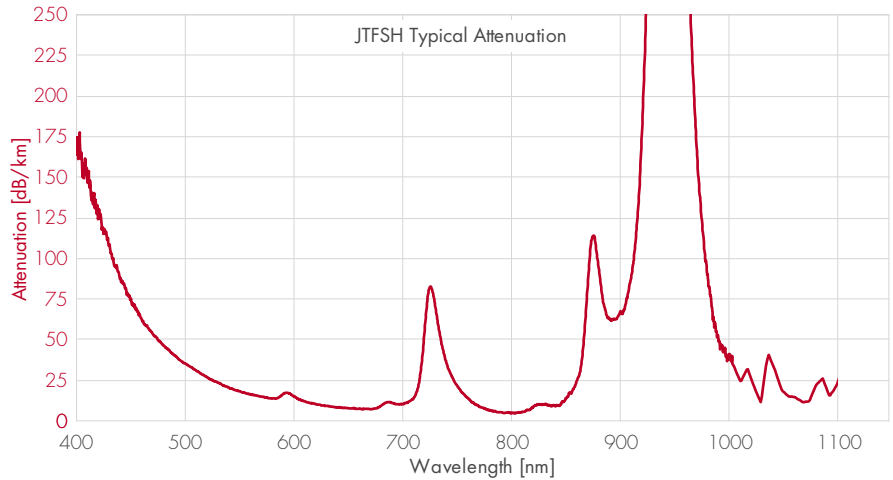

	Coating Material	Layers
Launch Fibers: 40µm, 50µm, 105µm with NA 0.15 and 0.22	Acrylate / High-Temperature Acrylate (HTA)	3
FVP Fiber: 50–1000µm / NA 0.22	Polyimide (<600µm core-Ø); Acrylate (>800µm core-Ø)	3
JTFSH Fiber: 200–1000µm / NA 0.37	Tefzel / Acrylate; Nylon / Hytrel	3
JTFVH Fiber: 200–940µm / NA 0.22	Tefzel / Acrylate; Nylon / Hytrel	4

VIS-NIR Fibers

VIS-NIR fibers are among the so-called low-OH fibers. As a rule, they can be used up to a wavelength of 1900 nm. These fiber types are also standard fibers that can be found in many different areas of application, such as data and power transmission, sensor technology, and illumination. In diode lasers, they are used to transmit typical pump wavelengths of 808–980 nm.

The silica core is optionally surrounded by a coating made of silica or hard cladding materials. The fiber is available in different numerical apertures. Tefzel, polyimide, acrylate, and nylon are used as special buffer materials.

Double-clad fibers with a second coating (usually a hard-clad polymer coating) are used especially for the transmission of high power. This additional layer guarantees that the power is transmitted reliably, even with strongly bent fibers. In addition, these fibers can be used to guide cladding modes in small quantities.

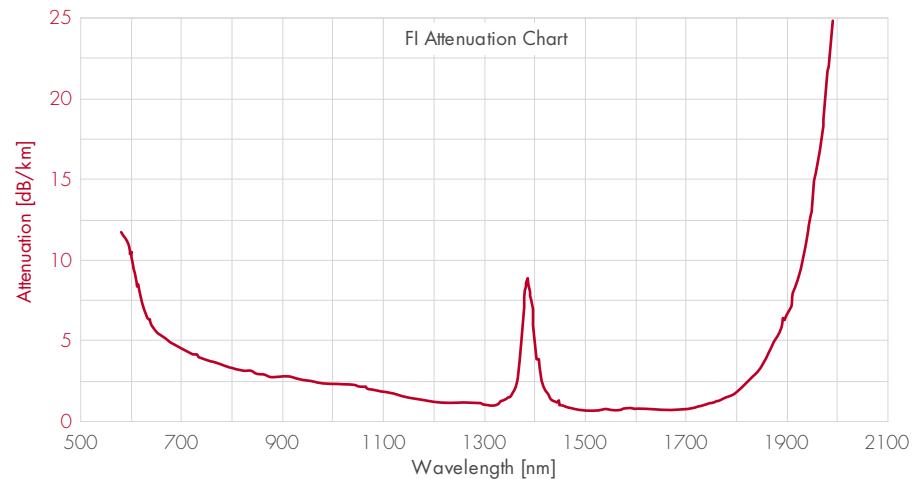
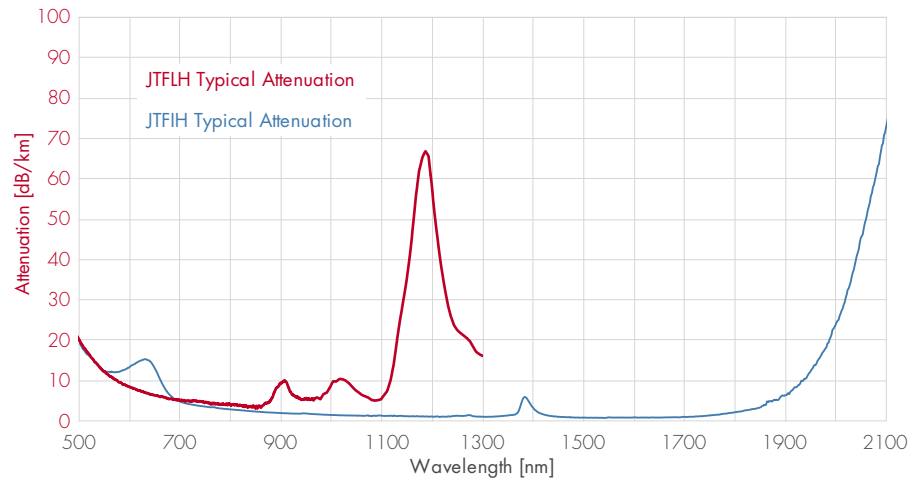

	Coating Material	Layers
Launch Fibers: 40 μm , 50 μm , 105 μm with NA 0.15 and 0.22	Acrylate / High-Temperature Acrylate (HTA)	3
FI Fiber: 50–1000 μm / NA 0.22	Polyimide (< 600 μm core- \varnothing); Acrylate (> 800 μm core- \varnothing)	3
JTFLH Fiber: 200–1000 μm / NA 0.37	Tefzel / Acrylate; Nylon / Hytrel	3
JTFIH Fiber: 200–940 μm / NA 0.22	Tefzel / Acrylate; Nylon / Hytrel	4

MM Fibers – Gradient Index

Gradient index (GI) fibers are mainly used for data transmission. Typical applications include local area networks (LAN) and industrial data transmission.

Features

With gradient index fibers, the refractive index changes across the cross-section of the fiber. The refractive index decreases exponentially from the center of the core to the cladding. This counteracts the effect of mode dispersion. Therefore, they achieve a higher bandwidth than step index fibers. In addition, they exhibit a lower pulse distortion at a comparable numerical aperture.

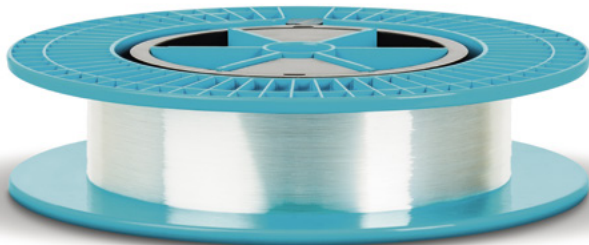

GI/MM Fibers for Extreme Environments

Gradient Index Multimode Fibers with a Pure Silica Core

These germanium-free gradient index fibers with a core diameter of 50 μm offer the best performance even in hydrogen-rich and radiation-intensive environments. With their unique glass chemistry and carbon coating with high-temperature acrylate or polyimide, they provide optimum transmission performance even at temperatures of up to 150 °C (acrylate) or 300 °C (polyimide).

Even if severely bent, these fibers remain intact. In addition, the coating ensures that water, acid, and other liquids do not penetrate the fiber and cause microcracks in the fiber core.

Since the robust fibers can withstand high pressure, moisture, chemicals and radiation, they are used for measurement and monitoring technologies in oil and gas production, among other applications.

Product Variants	GIMMSC(50/125)HT	GIMMSC(50/125)CHT	GIMMSC(50/125)P	GIMMSC(50/125)CP
Operating Wavelength [nm]	600–1750			
Numerical Aperture	0.18–0.223			
Core Diameter [μm]	50			
Cladding Diameter [μm]	125 \pm 1	125 \pm 2	125 \pm 1	125 \pm 2
Coating Diameter [μm]	245 \pm 15		155 \pm 5	
Coating Type	High-Temperature Acrylate	Carbon/High-Temperature Acrylate	Polyimide	Carbon/Polyimide

Pure Silica GI/MM

Gradient Index Multimode Fibers with a High-Temperature Acrylate Coating

These powerful germanium-doped gradient index fibers with core diameters of 62.5 μm and 50 μm are used, among other things, in sensor applications with high bandwidths. Thanks to their high-temperature acrylate coating, they can even withstand extreme mechanical stress and temperatures of up to 150 $^{\circ}\text{C}$.

Product Variants	GIMM(50/125)HT	GIMM(62.5/125)HT
Operating Wavelength [nm]	800–1750	
Numerical Aperture	0.18–0.22	0.25–0.30
Core Diameter [μm]	50	62.5
Cladding Diameter [μm]	125 \pm 1	
Coating Diameter [μm]	245 \pm 15	
Coating Type	High-Temperature Acrylate	



© Fibercore

Single Mode Fibers

Compared to multimode (MM) fibers, single mode (SM) fibers have a very small core diameter that only transmits a single mode of coupled light. All other modes are not available. The coupled signal, therefore, remains nearly loss-free across long distances. For this reason, single mode fibers have also been established as telecommunication fibers in order to be able to carry signals of the wavelengths 1310nm and 1550nm unamplified for more than 100km.

In addition to single mode fibers, which are optimized for these so-called telecom wavelengths, there are also versions available for other wavelengths. They are required for special applications, for example for light transmission with very high beam quality or when small bending radii are required for single mode transmission.

Fiber Types and Applications:

- SM fibers for VIS-NIR wavelengths (page 067)
- Pigtails for erbium-doped fiber amplifiers (page 067)
- High-temperature SM fibers
 - Acrylate-coated fibers for ambient temperatures of up to 150 °C (page 069)
 - Polyimide-coated fibers for ambient temperatures of up to 300 °C (pages 068, 070, 073)
 - Dual-band carbon-coated fibers for harsh environments (page 071)
- Fibers with a pure-silica core (page 071)

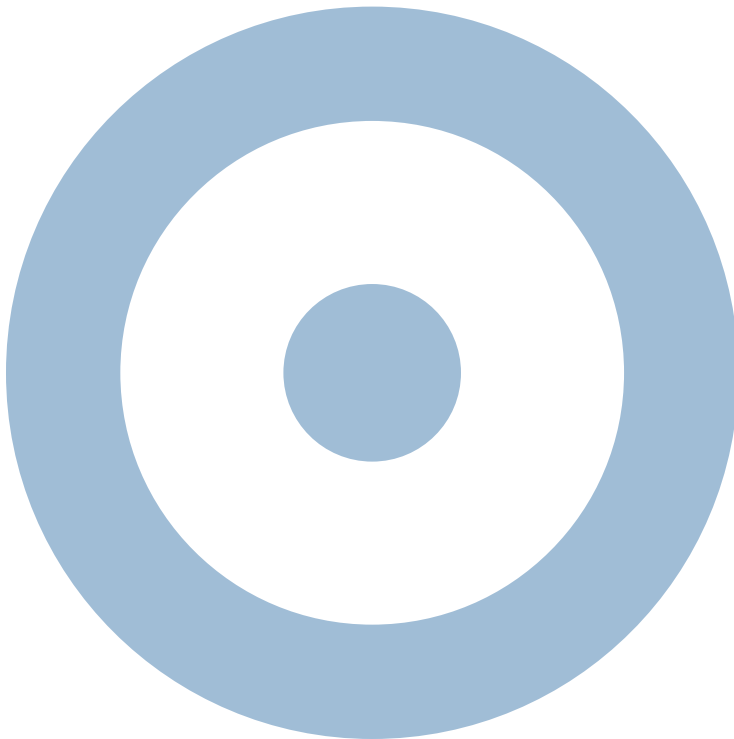

VIS-NIR Single Mode Fibers

VIS-NIR single mode fibers have a comparatively high numerical aperture to guarantee low attenuation even in tight bends. This also reduces the static fatigue of these fibers more than with standard telecom fibers. They can, therefore, be packed

more tightly and are particularly suitable for coil sensors and the next generation of miniaturized telecommunications devices.

For fibers with a reduced cladding diameter, static fatigue during winding

is reduced, and the mechanical lifetime increases for small winding diameters.

Typical applications include geophones, Fiber Bragg Gratings (FBGs), and sensors.

Product Variants	SM450	SM600	SM750	SM800 (5.6/125)	SM980 (3.7/125)	SM980 (4.5/125)	SM980 (5.8/125)
Operating Wavelength [nm]	488–633	633–780	780–830	830–980	980	980–1550	
Cut-Off Wavelength [nm]	350–450	500–600	610–750	660–800	870–970		
Numerical Aperture	0.10–0.14				0.21–0.23	0.17–0.19	0.13–0.15
Mode Field Diameter [μm]	2.8–4.1 @ 488 nm	3.6–5.3 @ 633 nm	4.5–6.5 @ 780 nm	4.7–6.9 @ 830 nm	3.4–4.0 @ 980 nm	4.2–4.9 @ 980 nm	5.3–6.4 @ 980 nm
Coating Type	Dual Acrylate						

Product Variants	SM1500 (4.2/125)	SM1500 (6.4/125)	SM1500 (7.8/125)	SM1500 (9/125)	SM1500ES (3/125)	SM800 (4.2/80)	SM980 (4.5/80)
Operating Wavelength [nm]	1520–1650				1510–1650	830–980	980–1550
Cut-Off Wavelength [nm]	1350–1520				1400–1500	660–800	870–970
Numerical Aperture	0.29–0.31	0.19–0.21	0.15–0.17	0.13–0.15	0.38–0.42	0.14–0.18	0.17–0.19
Mode Field Diameter [μm]	4.0–4.5 @ 1550 nm	6.0–6.8 @ 1550 nm	7.4–8.6 @ 1550 nm	8.5–9.9 @ 1550 nm	4.0–4.5 @ 1550 nm	3.8–4.9 @ 830 nm	4.2–4.9 @ 980 nm
Coating Type	Dual Acrylate				Acrylate	Dual Acrylate	

Product Variants	SM1250 (5.4/80)	SM1250 (9/80)	SM1500 (4.2/50)	SM1500 (4.2/80)	SM1500 (5.3/80)	SM1500 (6.4/80)	SM1500 (7.8/80)
Operating Wavelength [nm]	1310–1550		1520–1650				
Cut-Off Wavelength [nm]	1150–1250		1350–1520				
Numerical Aperture	0.19–0.21	0.11–0.13	0.29–0.31		0.23–0.25	0.19–0.21	0.15–0.17
Mode Field Diameter [μm]	5.0–5.7 @ 1310 nm	8.2–9.9 @ 1310 nm	4.0–4.5 @ 1550 nm		4.0–4.5 @ 1550 nm	6.0–6.8 @ 1550 nm	7.4–8.6 @ 1550 nm
Coating Type	Dual Acrylate		Acrylate	Dual Acrylate			

High-Temperature SM Fibers

Dual-Band Carbon-Coated SM Fiber

DBCC SM fibers withstand extreme environmental conditions such as high temperatures, high pressure, liquids, and chemicals. This facilitates, for example, pressure monitoring, data transmission, offshore monitoring, and many other applications in the oil and gas industry.

Depending on the additive material, the hermetic carbon coating developed by the manufacturer prevents water, acid, and other liquids from penetrating into the fiber at temperatures of up to 150 °C (acrylate) and 300 °C (polyimide). In addition, the cladding protects the fiber core from mechanical damage and ensures a long lifespan even in the event of severe bending.

Nevertheless, it can be removed quickly and easily with conventional tools.

Product Variants	SM1250(10.4/125)CHT	SM1250(10.4/125)CP
Operating Wavelength [nm]	1260–1650	
Cut-Off Wavelength [nm]	1190–1330	
Numerical Aperture	0.11–0.14	
Mode Field Diameter [μm]	9.6–11.2	
Coating Type	Carbon/High-Temperature Acrylate	Carbon (Polyimide)



SM Fibers with a High-Temperature Acrylate Coating

Single mode fibers with a high-temperature acrylate coating are designed for permanent use at temperatures of up to +150 °C. Depending on the application, versions with different mode-field diameters are available. The bending loss can be influenced by a selection of numerical apertures.

With its low attenuation, the SM1500-(9/125)HAT is ideally suited for power transmission or distribution in fiber optic sensor systems. Due to its higher cut-off wavelength, it has significantly lower bending losses than standard telecom fibers.

The 6.3 μm and 7.8 μm MFD versions feature particularly low macro and micro-bending losses and higher backscattering coefficients for Raman, Rayleigh, and Brillouin sensor systems. When spliced, they are particularly compatible with small MFD sensor coil fibers with high numerical apertures. For example, they are often used as “bridging fibers” in acoustic sensors.

Product Variants	SM1500 (5.3/80)HT	SM1500 (6.4/80)HT	SM1500 (6.4/125)HT	SM1500 (7.8/1225)HT	SM1500 (9/125)HT
Operating Wavelength [nm]	1520–1650				
Cut-Off Wavelength [nm]	1350–1520				
Numerical Aperture	0.23–0.24	0.19–0.21		0.15–0.17	0.13–0.15
Mode Field Diameter [μm]	5.0–5.6 @ 1550nm	6.0–6.8 @ 1550nm		7.3–8.3 @ 1550nm	8.5–9.9 @ 1550nm
Coating Type	High-Temperature Acrylate				

SM Fibers with a Polyimide Coating

Polyimide-coated, bending-resistant single mode (SM) fibers are designed for continuous use up to 300 °C and can withstand peak temperatures of up to 400 °C for short periods. Therefore, they are used especially in extreme environmental conditions (e.g., in micro-seismic fracking sensors). They are also particularly suitable as FBG fibers for stress and temperature sensors.

The fibers are available with different numerical apertures between 0.13 and 0.31. Fibers with a low NA are suitable for applications in which only low attenuation losses are allowed in straight fibers across long distances. Fibers with a high NA are used wherever bending losses should be as low as possible when rolled up.

Product Variants	SM1250 (10.4/125)P	SM1500 (4.2/125)P	SM1500 (6.4/125)P	SM1500 (7.8/125)P	SM1500 (9/125)P
Operating Wavelength [nm]	1260–1650	1520–1650			
Cut-Off Wavelength [nm]	1190–1330	1350–1520			
Numerical Aperture	0.11–0.14	0.29–0.31	0.19–0.21	0.15–0.17	0.13–0.15
Mode Field Diameter [μm]	9.6–11.2 @ 1550nm	4.0–4.5 @ 1550nm	6.0–6.8 @ 1550nm	7.4–8.6 @ 1550nm	8.5–9.9 @ 1550nm
Coating Type	Polyimide				

Product Variants	SM1500 (4.2/50)P	SM1500 (4.2/80)P	SM1500 (5.3/80)P	SM1500 (6.4/80)P	SM1500 (7.8/80)P
Operating Wavelength [nm]	1520–1650				
Cut-Off Wavelength [nm]	1350–1520				
Numerical Aperture	0.29–0.31		0.23–0.25	0.19–0.21	0.15–0.17
Mode Field Diameter [μm]	4.0–4.5 @ 1550nm		5.1–5.6 @ 1550nm	6.0–6.8 @ 1550nm	7.4–8.6 @ 1550nm
Coating Type	Polyimide				

SM Fibers with a Quartz Core

So-called pure-silica core SM (SM-SC) fibers are used to transmit high laser power in demanding applications. Thanks to a fluorinated cladding developed by the manufacturer, the fiber core can be made of pure quartz glass without the typical germanium doping.

The SM1250SC(9/125) and SM1500SC versions are particularly suitable for use in hydrogen-rich environments because the quartz core does not turn blind due to the reaction with hydrogen (hydrogen darkening). The SM300-SC and SM400-SC versions are suitable for the transmission of visible and ultraviolet wavelengths.

Their silicon core prevents the photo-darkening effect that normally occurs with germanium-doped fibers.

A fluorinated cladding with a recessed design makes a pure silicon core possible without the need for germanium doping.

Product Variants	SM300-SC	SM400-SC	SM1250SC(10/125)*	SM1500SC(7/80)	SM1500SC(7/125)
Operating Wavelength [nm]	320–430	405–532	1260–1650	1520–1650	
Cut-Off Wavelength [nm]	≤310	≤400	1190–1330	1350–1520	
Numerical Aperture	0.12–0.14		0.11–0.14	0.17–0.19	
Mode Field Diameter [μm]	2.0–2.4 @ 350nm	2.5–3.4 @ 480nm	9.2–10.8 @ 1550nm	6.7–7.6 @ 1550nm	
Coating Type	Dual Layer Acrylate		Dual Layer Acrylate, Polyimide*, Carbon/High- Temperature Acrylate, Carbon/Polyimide	Dual Layer Acrylate, Polyimide	Dual Layer Acrylate, Polyimide, Carbon/ High-Temperature Acrylate, Carbon/Polyimide

* Special polyimide, for strip and recoat FBGs, available.

Polarization-Maintaining (PM) Fibers

Standard PM Fibers

Polarization-maintaining (PM) fibers were developed to keep the polarization as stable as possible at wavelengths from 488nm to over 1550nm. These fibers can be found in interferometric sensors, modulators, delay lines, spectroscopy, and biomedical engineering.

Bow-Tie PM Fibers

In the bow-tie design, the fiber core is flanked on two sides by so-called stress-applying parts (SAPs) made of boron-doped glass, which have a significantly higher thermal expansion coefficient than the surrounding quartz glass.

The resulting stress creates two zones: one with a high and one with a low refractive index, which are perpendicular to each other. The birefringence generated in this way allows the polarization alignment to be controlled across the entire fiber system.

Product Variants	HB450	HB600	HB750	HB800	HB1000	HB1250	HB1500
Operating Wavelength [nm]	488–633	633–780	780–830	830–1060	1060–1300	1300–1550	1520–1650
Cut-Off Wavelength [nm]	350–470	500–600	610–750	600–800	840–1020	1030–1270	1230–1520
Mode Field Diameter [μm]	3.0–4.1	2.8–3.7	3.5–4.6	3.7–4.9	4.8–6.3	5.8–7.9	7.0–9.2
	@488nm	@633nm	@780nm	@830nm	@1060nm	@1310nm	@1550nm
Coating Type	Dual Layer Acrylate						

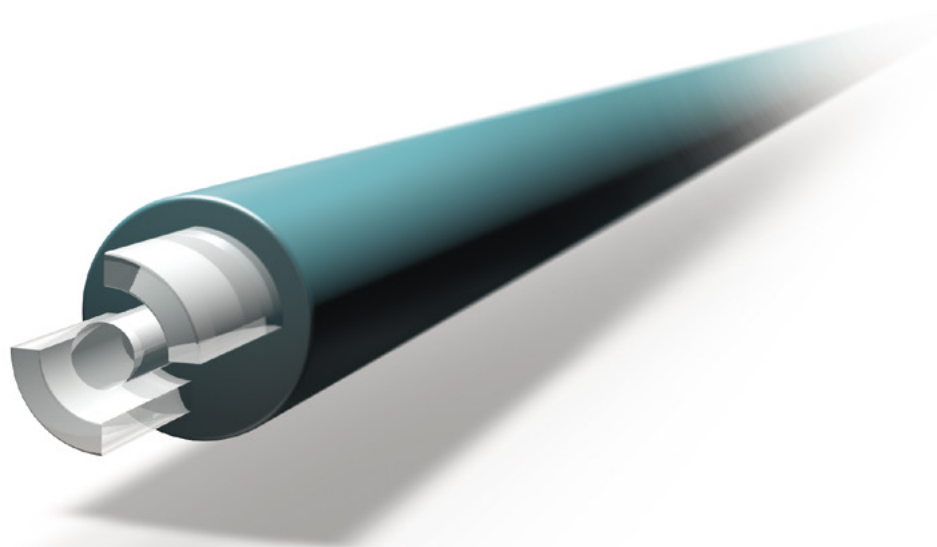

Polarization-Maintaining Polyimide Fibers

Polyimide-coated PM fibers (HB-P) can permanently withstand temperatures of up to 300 °C and even 400 °C for short periods. They are ideal for medical and sensory applications in which the fibers are sterilized at high temperatures or exposed to the curing temperatures of high-performance coating materials.

Polyimides are high-performance polymers and are mainly used in electronics. The polyimide coating is chemically bonded to the fiber surface and consists of an extremely robust, chemically resistant material that protects the fiber at a layer thickness of only 10 μm. A standard acrylate coating would be at least four times as

thick for the same fiber. This thin protective layer means that the fiber takes up very little space and is therefore suitable for smart skins and similar applications. Due to the particularly high adhesion between glass core and cladding, they are also ideally suited for the transmission of mechanical stresses in fiber optic sensor systems.

Product Variants	HB800P	HB1250P	HB1500P
Operating Wavelength [nm]	830–1200	1300–1550	1520–1650
Cut-Off Wavelength [nm]	600–800	1030–1270	1230–1520
Mode Field Diameter [μm]	3.7–5.0 @830nm	5.8–7.8 @1310nm	7.0–9.2 @1550nm
Coating Type	Polyimide		

PM Fibers – Telecommunications

Telecom PM fibers (HB-T) are adapted to the modes of standard telecom fibers. Splicing losses can be reduced to less than 0.1 dB. The extinction ratio of polarization is below -32 dB. At the same time, HB-Ts are particularly suitable for 45° splices in the manufacture of Lyot depolarizers due to their geometric precision.

The HB1250T, HB1480T, and HB1500T versions are also available with a double 400µm acrylate buffer, which makes the fiber even more robust and reduces the degradation of the extinction ratio of the polarization within the application.

HB980T and HB1480T were developed for use in polarization multiplexing and the pigtailling of pump diodes.

HB14XXT, HB1250T (9/125), and HB980T (6.6/125) are fibers with a short beat length that are especially suited for Raman pump depolarizers and PM pigtails.

Product Variants	HB980T	HB1250T (245)	HB1250T (400)	HB1480T (245)	HB1480T (400)	HB1500T (245)	HB1500T (400)
Operating Wavelength [nm]	980–1310	1300–1480		1480–1550		1520–1650	
Cut-Off Wavelength [nm]	870–970	1100–1290		1290–1450		1290–1520	
Mode Field Diameter [µm]	5.3–6.4 @980nm	8.1–9.9 @1310nm	9.1–10.8 @1480nm	9.6–11.7 @1550nm	4.8–6.3 @1060nm	5.8–7.9 @1310nm	7.0–9.2 @1550nm
Beat-Length [nm] @633nm	≤2.0						
Coating Type	Dual Layer Acrylate						

Ultra-short Beat-Length	HB980T(6.6/125)	HB1250T(9/125)	HB14XXT
Operating Wavelength [nm]	980–1310	1260–1650	1300–1650
Cut-Off Wavelength [nm]	870–970	1100–1250	1100–1290
Mode Field Diameter [µm]	6.1–7.1 @980nm	8.1–9.9 @1310nm	9.5–11.5 @1465nm
Beat-Length [nm] @633nm	≤1.2		
Coating Type	Dual Layer Acrylate		

PM Gyro Fibers

In fiber optic gyroscopes (FOGs), the bow-tie-shaped arrangement of stress-applying parts (SAPs) ensures that the tension is efficiently focused on the core of the polarization-maintaining fiber. The high birefringence also guarantees a consistently high extinction ratio of polarization. In addition, the coating, which is optimized for gyroscopes, ensures a world-leading level of performance.

We also supply PM gyro fibers with a low beat length (high extinction ratio), high numerical aperture (insensitive to bending with tight winding), and radiation-resistant designs for aerospace applications.

High Extinction Ratio in a Temperature Range from -55 °C to +85 °C

The power is maintained across a wide temperature range. Under test conditions, extinction ratios of over 30dB (h-parameters of $1 \times 10^{-5} \text{ m}^{-1}$) were maintained to -55 °C. Similarly, extinction ratios of over 28 dB were able to be demonstrated to -60 °C.

Product Variants	HB800G	HB1250G	HB1500G	HB1500G-RT	HB1500G-HI
Operating Wavelength [nm]	810–1000	1280–1520	1520–1650		
Cut-Off Wavelength [nm]	660–800	1030–1270	1230–1520		1360–1520
Mode Field Diameter [μm]	3.7–4.9 @830nm	5.8–7.8 @1310nm	6.9–9.3 @1550nm		6.0–6.9 @1550nm
Beat-Length [nm] @633 nm	≤ 1.5				
Coating Type	Dual Layer Acrylate				

Short Beat-Length	HB800G-SB	HB1500G-SB	HB1500G-RT-SB
Operating Wavelength [nm]	810–1000	1520–1650	
Cut-Off Wavelength [nm]	660–800	1360–1520	
Mode Field Diameter [μm]	3.7–5.0 @830nm	6.0–7.0 @1550nm	
Beat-Length [nm] @633 nm	≤ 1.0		≤ 1.15
Coating Type	Dual Layer Acrylate		

PM Fibers with a Quartz Glass Core

Polarization-maintaining fibers with a quartz glass core (HB450-SC) can transmit ultraviolet (UV), violet, blue, and green wavelengths without the photodarkening effect associated with standard germanium-doped fibers.

Typical applications include environmental monitoring and biomedical applications such as confocal microscopy, DNA sequencing, and flow cytometry. The fiber is designed to be compatible with

fibers with coreless end caps (MM125) that expand the output beam to counteract excessive power density at the fiber end.

Product Variants	HB450-SC
Operating Wavelength [nm]	430–650
Cut-Off Wavelength [nm]	350–420
Mode Field Diameter [μm]	3.0–3.6 @488 nm
Beat-Length [nm] @633 nm	≤ 2.5

Bow-Tie Zing PM Fibers

Zing Fiber Polarizers

Zing fibers are special fiber-based polarizers that only allow one polarization state to pass through. Both straight and curved fibers provide a very good extinction ratio (PER) and a wide and stable application window as required by many applications.

Such performance is due to the extreme birefringence that only a polarization-maintaining fiber with bow-tie geometry can produce. With beat lengths of nearly 0.5 mm at 633 nm, the Zing fiber polarizer offers a practical polarization bandwidth of 100 nm and numerous options for packaging and light source: wired or coiled, narrow line width, laser, and broadband amplified spontaneous emission (ASE).

By changing the fiber length and/or coil diameter, the central wavelength and the width of the working window can be adjusted. Zing fibers are available with numerous packaging and light source options.

Product Variants	HB830Z (5/80)	HB1060Z (7/125)	HB1310Z (9/80)	HB1550Z (11/80)	HB1550Z (11/80)-50mm*	HB1550Z (11/125)
Operating Wavelength [nm]	830	1064	1310	1550		
Mode Field Diameter [μm]	4.1–7.7 @830nm	6.0–8.0 @1064nm	7.0–10.3 @1310nm	8.5–13.5 @1550nm		10.0–12.5 @1550nm
Cladding Diameter [μm]	80 \pm 1	125 \pm 1	80 \pm 1			125 \pm 1
Coating Diameter [μm]	170 \pm 5	245 \pm 7	170 \pm 5			245 \pm 7
Coating Type	Dual Layer Acrylate					

Multicore Fibers

Standard Multicore Fibers

Multicore fibers are gaining increasing importance, especially in sensor systems and telecommunications. Multicore fibers considerably reduce the number of cables and connections in data centers and switching centers. Through space division multiplexing (SDM) and combining several signal lines in a single slot, higher bandwidths can be achieved with fewer cables.

In Multicore fibers for biomedical applications, the fiber has photosensitive cores into which Fiber Bragg Gratings (FBGs) can be written. They are therefore suitable for use as 3D shape sensors to determine the exact position of catheters and other medical devices in minimally invasive procedures.

Multicore fibers are manufactured using a process that can be quickly and easily adapted to special customer requirements. Deviating from the standard product, designs with individual core numbers and positions are also possible, as well as combinations of SM and MM cores.

Product Variants	SM-4C1500(8.0/125)/001	SM-7C1500(6.1/125)	SSM-7C1500(6.1/125)
Operating Wavelength [nm]	1520–1650		
Cut-Off Wavelength [nm]	1300–1500		
Numerical Aperture	0.14–0.17	0.20–0.22	
Mode Field Diameter [μm]	7.4–8.5 @1550nm	5.7–6.5 @1550nm	
Number of Cores	4	7	7
Core Position Shape	Square	Hexagon plus central core	Hexagon plus central core Spun

Fiber Optic Fan-Outs

Multicore fan-outs consist of several individual single mode fibers that are bundled on the input end to a Multicore fiber on the output end. It is possible to achieve particularly efficient optical fiber

coupling with 3D waveguide technology. This minimizes insertion loss, polarization-related losses (≤ 1.0 dB each), and undesired secondary signal effects (≤ -50 dB). This flexible process makes it possible for

the manufacturer to optimally position the fiber cores for individual customer solutions. At the same time, it can be easily scaled for producing large quantities.

Product Variants	FAN-4C	FAN-7C
Operating Wavelength [nm]	1550	
Number of Cores	4	7
Core Configuration	Square	Hexagonal plus central core
Input Fiber Type	SMF-28 or equivalent	
Output Fiber Type	SM-4C1500(8.0/125)/001	SM-7C1500(6.1/125) SSM-7C1500(6.1/125)

Doped and Photosensitive Fibers

Photosensitive Fibers

Photosensitive (PS) fibers are doped with boron and germanium. The combination of these two elements allows a high degree of light sensitivity with a relatively high

mode-field diameter. This makes it possible to quickly inscribe highly reflective Fiber Bragg Gratings (FBGs) without having to enrich the fiber with hydrogen beforehand.

This saves a significant amount of time especially in the series production of FBGs (e.g., in the production of FBG stabilizers for diode lasers).

Product Variants	PS750	PS980	PS1250/1500
Operating Wavelength [nm]	780–980	980–1310	1260–1650
Cut-Off Wavelength [nm]	610–750	850–950	1100–1260
Numerical Aperture	0.12 – 0.14		
Mode Field Diameter [μm]	4.4–5.9 @780nm	5.6–6.8 @980nm	8.8–10.6 @ 1550nm
Attenuation [dB/km]	30 (typical) @780nm	20 (typical) @980nm	10 (typical) @1310nm 120 (typical) @1550nm

Doped Fibers

Highly Germanium-Doped Fibers

Highly germanium-doped fibers are mainly used in the production of FBG arrays that are not affected by bending. Their cores contain five times more germanium than commercially available telecom fibers. Thus, the FBGs can also be inscribed without first enriching them with hydrogen.

With their high numerical aperture, these fibers are particularly resistant to bending losses. Fibers are also available on an optional basis with low cladding diameters of 50 μm and 80 μm that can be wound particularly tightly and at the same time have a long lifespan. They are used, for example, in optical hydrophones and geophones.

Special coating types are available upon request in which FBGs can be inscribed directly into the fiber without having to remove the coating beforehand.

Product Variants	SM1500(4.2/50)	SM1500(4.2/80)	SM1500(4.2/125)
Operating Wavelength [nm]	1520–1650		
Cut-Off Wavelength [nm]	1350–1500		
Numerical Aperture	0.29–0.31		
Mode Field Diameter [μm]	4.0–4.5 @1550nm		
Cladding Diameter [μm]	50 \pm 1	80 \pm 1	125 \pm 1

Erbium/Ytterbium-Doped Double-Clad Fibers

Erbium/ytterbium-doped double-clad fibers were designed as amplifying fibers for high-power communication. The pump light is directed through a full-silica structure.

A second fluorinated cladding forms the boundary for the pump light, eliminating the need for polymers with a low refractive index. This makes the fiber more robust and resistant and usable regardless of temperature and ambient humidity.

The double cladding also makes on-site processing easier because the fiber does not have to be recoated after cleaving, splicing, or stripping.

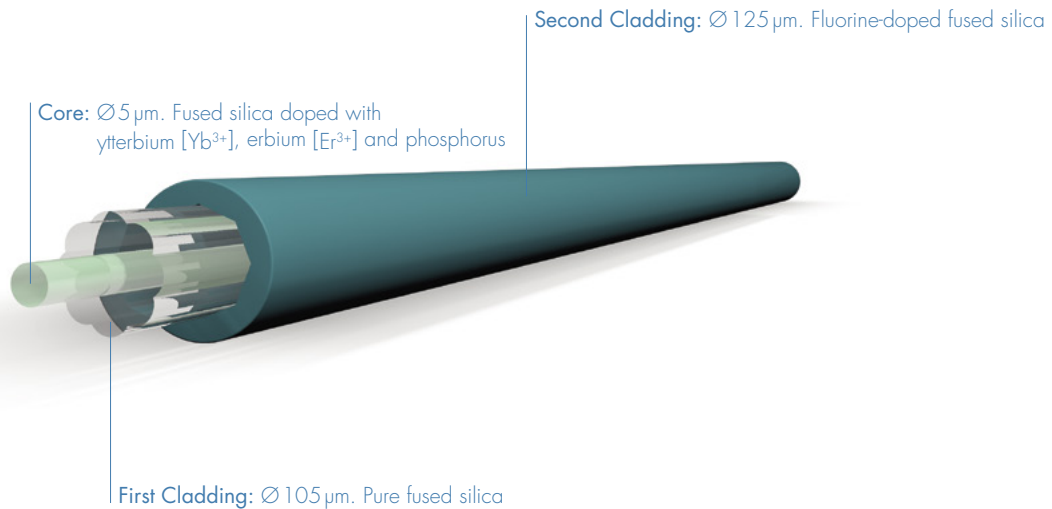

IsoGain – Erbium-Doped Fibers

At LASER COMPONENTS, you may choose from numerous erbium-doped fibers for your assemblies. The assortment includes different absorption and cut-off wavelengths. For each type of erbium-doped fiber amplifier (EDFA) the best possible selection of fibers is available.

Low-absorption fibers are specifically designed for C-band amplifiers, while fibers with a higher absorption are optimized for L-band EDFAs. Fibers with high cut-off wavelengths have larger fiber core diameters. This increases pumping performance and prevents non-linear effects.

The cores of the IsoGain fibers are designed to produce a highly flattened wavelength range. All fibers are coated with a double acrylate layer.

High Efficiency C-Band Erbium-Doped Fibers*	I-4(980/125)	I-4(980/125)HC	I-4(980/125)HP	I-6(980/125)
Cut-Off Wavelength [nm]	870–970	1050–1320	1100–1320	870–970
Numerical Aperture	0.22–0.24		0.19–0.22	0.22–0.24
Mode Field Diameter [μm]	5.4–6.6 @1550nm	5.2–5.8 @1550nm	5.7–6.6 @1550nm	5.5–6.3 @1550nm

L-Band and C-Band Erbium-Doped Fibers*	I-12(980/125)	I-12(980/125)HC	I-15(980/125)HC	I-25(980/125)
Cut-Off Wavelength [nm]	900–970	1200–1320		900–970
Numerical Aperture	0.21–0.23	0.23–0.26		
Mode Field Diameter [μm]	5.7–6.6 @1550nm	5.0–5.5 @1550nm	4.8–5.4 @1550nm	5.2–6.3 @1550nm

Reduced Cladding Erbium-Doped Fiber* (for Mini and Micro EDFAs)	I-25H(1480/80)
Cut-Off Wavelength [nm]	900–1075
Numerical Aperture	≥ 0.30
Mode Field Diameter [μm]	3.8–4.7 @1550nm

* All detailed specifications can be found on the respective datasheets. Please visit our website.

Polarization-Maintaining Erbium-Doped Fibers

Polarization-maintaining erbium-doped fibers combine the core structure of erbium-doped fibers with bow-tie geometry from the field of highly birefringent PM fibers.

They were developed for mode-locked fiber lasers and other products in which polarization is to be maintained.

With its high peak absorption, this fiber type is particularly suitable for EDFAs with a low amplification length and research applications requiring very short active fiber ranges.

Product Variants	DHB1500	DHB1500-LA
Cut-Off Wavelength [nm]	860–960	
Numerical Aperture	0.22–0.26	0.22–0.24
Mode Field Diameter [μm]	5.1–6.7 @1550nm	5.5–6.7 @1550nm
Attenuation [db/m]	10 (nominal) @980nm 12–27 @1531 nm	10 (typical) @1310nm 120 (typical) @1550nm

Other Doped Fibers

The use of neodymium, erbium, and ytterbium makes it possible to produce doped fibers for laser and telecommunication applications with wavelengths between 1030nm and 1550nm.

Neodymium-doped DF1000 is the ideal introduction to fiber laser technology. Due to its particularly low laser threshold value, it can be operated with low-cost laser diodes (e.g., from CD players).

DF1100 is an ytterbium-doped single mode fiber with a high degree of doping. It was specially developed for pumping lasers in the wavelength range between 915 nm and 980nm. The high absorption rate is particularly suitable for pre-amplifiers or short amplification lengths with mode-locked ring lasers in the femto-second range.

The mixture of erbium and ytterbium extends the pump absorption band of the DF1500Y fiber from 915nm to 980nm. The absorption rate remains relatively low up to its peak value at 980nm. This enables the use of low-cost, non-stabilized 940nm pumps, in which temperature-dependent fluctuations in the pump wavelength have a much smaller influence on the output power.

Product Variants	DF1000	DF1100	DF1500Y
Operating Wavelength [nm]	1085	1030–1100	1550
Cut-Off Wavelength [nm]	875–1025	800–900	950–1050
Numerical Aperture	0.18–0.22	0.14–0.17	0.20–0.24
Mode Field Diameter [μm]	3.9–5.0 @1085nm	5.1–6.3 @1085nm	5.3–6.8 @1550nm
Dopants	Neodymium (Nd)	Ytterbium (Yb)	Erbium/Ytterbium (Er/Yb)

Spun Fibers

Measuring the Faraday Effect

Spun high-birefringence (HiBi) fibers have been optimized for use in polarimetric sensors. These include fiber optic AC and DC current transformers, which are increasingly replacing classic current transformers in power networks.

Even very long spun HiBi fibers can be wound into coils that are small in diameter. This makes it possible to measure the Faraday effect, for example. These fibers are produced by twisting polarization-maintaining bow-tie fibers during the drawing process. This design preserves circular polarization.

The fibers are thus insensitive to signal loss and drift caused by stress birefringence, such as that caused by vibrations or thermal influences.

Product Variants	SHB1250(7.3/80) - 2.5 mm	SHB1250(7.3/80)	SHB1250(7.3/125)	SHB1500(8.9/125)
Operating Wavelength [nm]		1260–1510		1510–1650
Cut-Off Wavelength [nm]		1100–1250		1360–1500
Numerical Aperture		0.14–0.17		0.13–0.16
Mode Field Diameter [μm]		6.2–8.4 @1310nm		7.9–9.9 @1550nm



Pump Fibers

All-Silica Double-Clad Fibers

The SMM900 passive double-clad fiber combines single mode (SM) and multimode (MM) properties in a multimode fiber. It consists of a germanium-doped all-silica SM fiber core and an inner cladding of pure quartz glass through which the pump beam is guided. A further fluorine-doped cladding makes this fiber particularly resistant to harsh environmental conditions.

It does not require a polymer coating with a low refractive index. Therefore, it can be processed like a standard telecom fiber and does not need to be recoated afterwards.

The SMM900 has been optimized for use with an erbium/ytterbium-doped CP1500Y double-clad fiber, an MM105 multimode pump fiber, and a CP-IWDM isolating wavelength division multiplexer. The optical properties of these fibers have been matched so that they can be spliced nearly loss free.

Product Variants	SMM900
Single Mode Core	
Cut-Off Wavelength [nm]	1100–1250
Mode Field Diameter [μm]	6.5–8.2 @1550nm
Pump Guide	
Numerical Aperture	0.24–0.28
Diameter [μm]	100–104

Passive Double-Clad Fibers with a Low Refractive Index

Passive double-clad fibers are available with a low refractive index for wavelengths of 1060nm and 1550nm (e.g., for fiber lasers, pump combiners, amplifiers, and sensor applications).

With a numerical aperture of 0.08 and a fiber core diameter of 10 μ m, DC1060(10/125)0.08HD offers significant power control advantages and high

nonlinear thresholds for 1060nm fiber laser applications.

DC1500(6/125)0.21HD and DC1500(11/125)0.12HD fibers have been developed in such a way that, in combination with an erbium/ytterbium-doped fiber amplifier at 1550nm, high-performance amplifiers with a particularly high degree of efficiency can be implemented.

The fluorinated acrylate cladding with a low refractive index is 245 μ m in diameter. The attenuation characteristics and mechanical resilience correspond to the criteria of the 85 °C/85 % humidity test carried out by Telcordia.

Product Variants	DC1060(10/125)0.08HD	DC1500(11/125)0.12HD	DC1500(6/125)0.21HD
Operating Wavelength [nm]	1060	1550	
Single Mode Core			
Cut-Off Wavelength [nm]	960–1040	1360–1520	1290–1520
Mode Field Diameter [μ m]	11.0 @1060nm (nominal)	9.5–11.5 @1550nm	5.6–6.5 @1550nm
Numerical Aperture	0.07–0.09	0.11–0.13	0.20–0.22
Pump Guide			
Attenuation [dB/km]	≤ 15 @1095 nm		
Numerical Aperture	0.45 (nominal)		

Sapphire Fibers

Versatilely Applicable:

Monocrystalline Sapphire Fibers

The sapphire fibers presented here are manufactured using the edge-defined film-fed growth (EFG) process. They possess the excellent material properties of sapphire crystal but are still flexible.

Sapphire has a very high melting point of over 2000 °C and is, chemically speaking, almost neutral. Sapphire fibers can, therefore, be used in aggressive environments without being damaged: for example, when monitoring chemical reactions in processing plants. They are also ideally suited for the transmission of Er:YAG laser beams.

Sapphire fibers can be manufactured with diameters of 100µm, 250µm, 325µm, and 425µm and lengths of up to two meters.

Product Features	
Fiber Diameter [$\mu\text{m} \pm 25 \mu\text{m}$]	425
Diameter with optional PTFE heat shrink buffer [μm]	750
Minimum Bend Radius [mm]	80
Fiber Length [m \pm 2 cm]	<2
Melting Point [°C]	2040
Tensile Strength [MPa]	275–400 (40–58 kpsi)
Compressive Strength [GPa]	2.0 (300 kpsi)
Effective NA	0.12

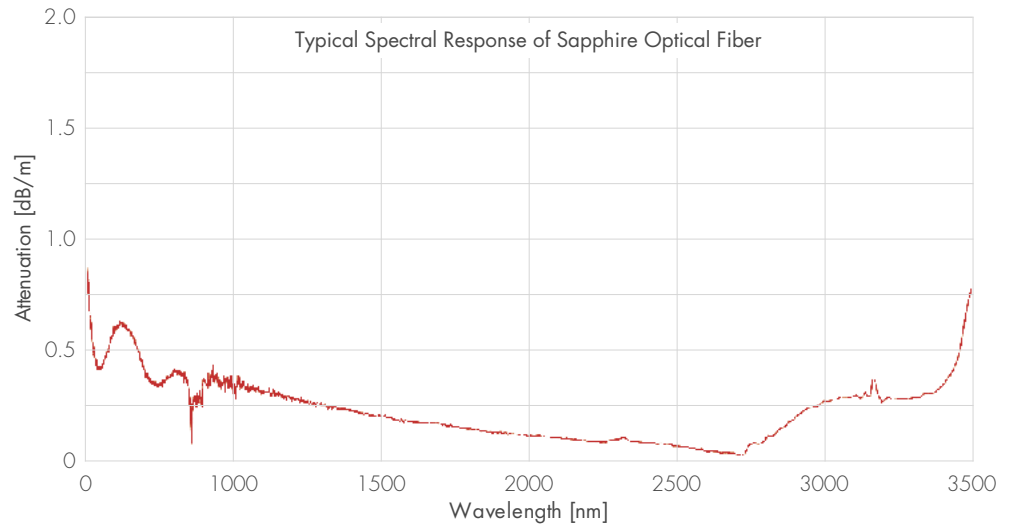

Plastic/POF Fibers and Cables

POF Fibers

Polymer optical fibers (POFs) are not only used for applications such as design lighting but also for signal transmission – e.g., in bus systems such as SERCOS (industrial measured values) and MOST (automotive networks).

Features

Plastic fibers are cheaper than glass fibers but also have a significantly higher attenuation. The typical value is 150 dB/km @ 650 nm. They are therefore mainly used in data transmission over short distances and in simple lighting tasks.

The fibers are available as bare fibers or finished cables, as well as with different core diameters. Outer diameters between 250 μm and 3000 μm are available on a standard basis.

PF Fibers

PF fibers have particularly good transmission properties. They are therefore ideally suited for data transmission over short distances.

PF fibers are also frequently used for lighting applications. However, the lower numerical aperture must be taken into account!

PG Fibers

PG fibers are the most common POFs. With a typical numerical aperture of 0.50, this fiber is particularly suitable for data transmission, illumination, and sensor technology.

! Optional

Also available as industrial cables.

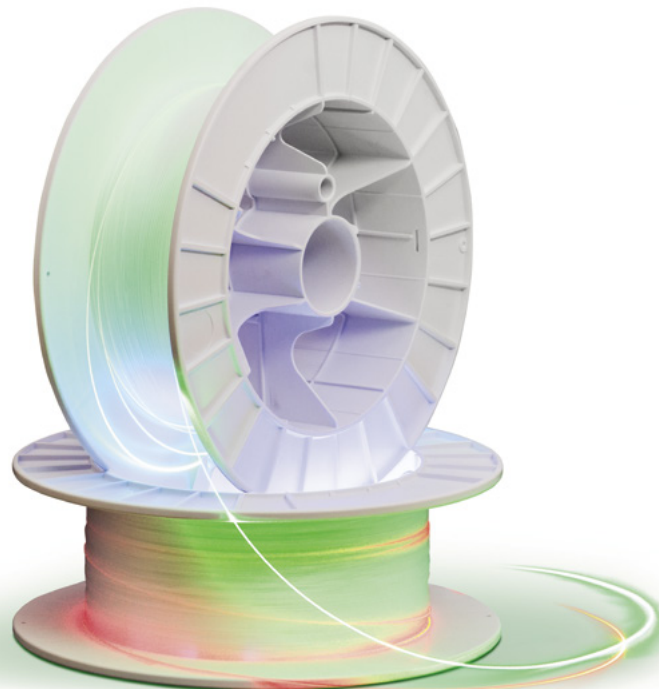

POF Cables

The robust cable assembly protects the fibers in POF cables from environmental influences. The application fields of the cables are almost identical to the application fields of the fibers.

POF cables are much simpler to use in assembly than glass fibers because the connectors can be crimped onto the cable buffer. Depending on the application, different cable diameters and cable materials are available.

All fiber types are also available as cable assemblies. Fiber bundles are available on a standard basis with up to 32 fibers in one cable buffer.

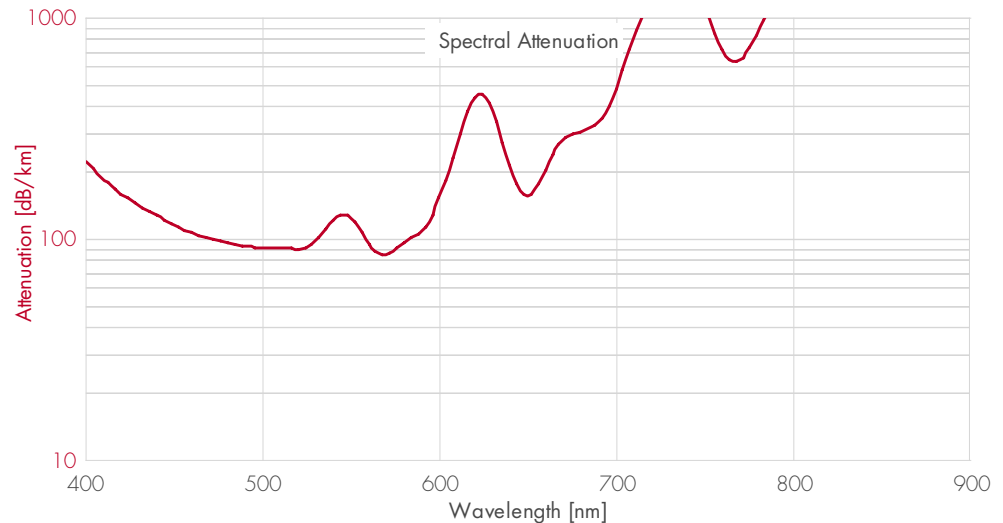

POF Cables

Fiber Core Diameter [μm]	250–2000 available as ready-made cables
Buffer Material	PE, PVC, PE (UL Grade VW-1), PVC (UL Grade VW-1), PA
Cable Diameter Simplex [mm]	1.0 / 1.5 / 1.8 / 2.2 / 2.3 / 2.8 / 3.0 / 5.0
Cable Diameter Zipcord [mm]	2.0 / 3.0 / 3.6 / 4.4
Cable Diameter Duplex [mm]	6.0
Cable Diameter for Fiber Bundles [mm]	1.0 / 1.3 / 2.2 / 2.8
Typical Attenuation for POF [dB/km]	150

Indoor and Outdoor LDF Multimode Cables

The use of optical fibers protected by a buffer is indispensable, especially in industrial and outdoor applications.

In general, a distinction is made between indoor and outdoor cables. Unfortunately, the variety of cable materials available for large diameter fibers (LDFs) is not as wide as for single mode and gradient index fibers used in telecom applications.

At LASER COMPONENTS, the majority of our fibers are available as industrial cables. For example, you can obtain UV fibers and broadband fibers with an NA of 0.22 in different cable versions. Please note that it is necessary to order a minimum quantity of 250–500 m of such special solutions.

LDF Multimode Cables Indoor and Outdoor

Fiber Core Diameter [μm]	50–1000
Numerical Aperture	0.22 / 0.37
Wavelength Range [nm]	190–1900
Buffer Material	PU, PVC (Riser) ¹ , PVC (Plenum) ² , LSZH
Cable Diameter Simplex [mm]	2.0 / 2.5 / 3
Cable Diameter Zipcord [mm]	4.6 x 2.2 / 5.2 x 3.2
Cable Diameter Duplex Oval [mm]	5.4 x 3.2
Cable Diameter Breakout [mm]	7.5 / 8 / 8.4 / 8.6 / 8.7
Possible Number of Channels	2–6

¹ Riser: Classified as OFNR types in the UL list (Underwriters Laboratories), these cables meet UL-1666 (vertical flame test) requirements. They are used for vertical installation, e.g. to connect different levels (floors).

² Plenum: Plenum cables are classified as OFNP types in the UL list and meet the requirements of the UL-910 (Steiner Tunnel) test, which includes flame propagation and smoke control. Applications are installation in shafts, air spaces and open or free installation in rooms without the use of installation pipes.

! Order Information

When ordering, please specify the complete cable length from front face to end face.

Cable Overview

- Patchcord Cable
- Pint to Point
- Internal Cabeling
- Fan-outs
- LAN Data Transmission Line

Simplex Cables

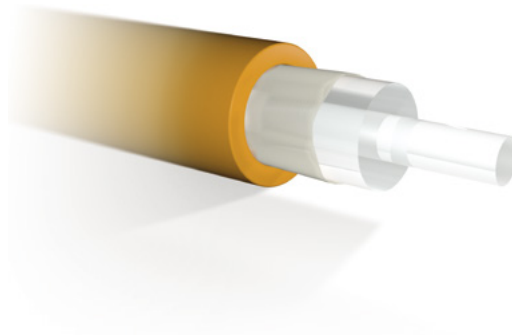

Simplex Cables

Construction	Application	Fiber Type	Cable Diameter [mm]	Outer Jacket Material	Channel Number	Temperature Range [°C]	Part Number
	Indoor	SI 200/230	3.0	PUR orange	1	-20~+80	3005785
	Indoor	SI 300/330	3.0	PUR black	1	-20~+80	3005295
	Indoor	SI 400/430	3.0	PUR orange	1	-20~+80	3003795
	Indoor	SI 600/630	3.0	PUR black	1	-20~+80	3006364
	Indoor	SI 200/230	2.2	PVC (OFNR) blue	1	-20~+60	3004728
	Indoor	SI 200/230	2.5	PVC orange	1	-20~+60	3002748

Duplex Cables

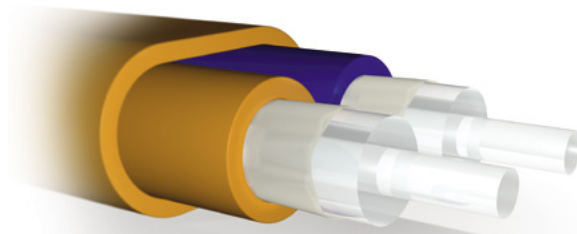



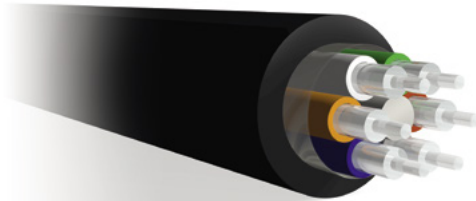

Duplex Cables								
Construction	Application	Fiber Type	Cable Diameter [mm]	Subunit	Outer Jacket Material	Channel Number	Temperature Range [°C]	Part Number
	Indoor	SI 200/230	4.6 x 2.2		PVC (OFNP) blue	2	-20~+60	3004985
	Indoor	SI 200/230	4.6 x 2.2		PVC (OFNR) blue	2	-20~+60	3003787
	Indoor	SI 200/230	$(5.2 \pm 0.4) \times$ (2.5 ± 0.2)		LSZH orange	2	-20~+70	3003823
	Indoor	SI 200/230	5.4 x 3.2	2.2	PVC orange	2	-20~+60	3003785
	Indoor/ Outdoor	SI 200/230	8.0	2.2	LSZH black	2	-20~+60	3003788
	Indoor/ Outdoor	SI 200/230	8.4	2.2	PVC black	2	-20~+60	3003786

Breakout Cables



Breakout Cables

Construction	Application	Fiber Type	Cable Diameter [mm]	Subunit	Outer Jacket Material	Channel Number	Temperature Range [°C]	Part Number
	Indoor/ Outdoor	SI 200/230	8.0	2.2	LSZH black	2	-20 ~ +60	3003788
	Indoor/ Outdoor	SI 200/230	8.4	2.2	PVC black	2	-20 ~ +60	3003786
	Indoor/ Outdoor	SI 200/230	7.5	2.2	PVC black	2	-20 ~ +60	3003789
	Indoor/ Outdoor	SI 200/230	7.5	2.2	PVC black	4	-20 ~ +60	3004986
	Indoor/ Outdoor	SI 200/230	8.7	2.2	PVC black	6	-20 ~ +60	3006178

Hollow-Core Fibers

Fibers for Infrared Radiation

Conventional quartz glass fibers have good transmission at wavelengths of up to 1800 nm. From 2000 nm, however, the absorption is so strong that modified optical fibers should be used. So-called hollow-core fibers are ideal for this purpose.

Hollow-Core Fibers

Hollow-core fibers consist of a quartz glass tube with an inner diameter between 500 μm and 1000 μm . The inside of this capillary is equipped with a silver mirror coating, followed by a layer of silver iodide. This creates an efficient dielectric IR reflector that can be optimized for wavelength ranges between 3 μm and 20 μm .

Hollow-core fibers are often used with CO₂ lasers for laser marking, printing, and cutting. In such industrial applications, the robust design of these fibers with their protective cover made of acrylate at one end is a crucial advantage because the transmission properties remain constant even under adverse environmental conditions.

These fibers can be used at powers of up to 60 W without external cooling. The power can be increased with external cooling.

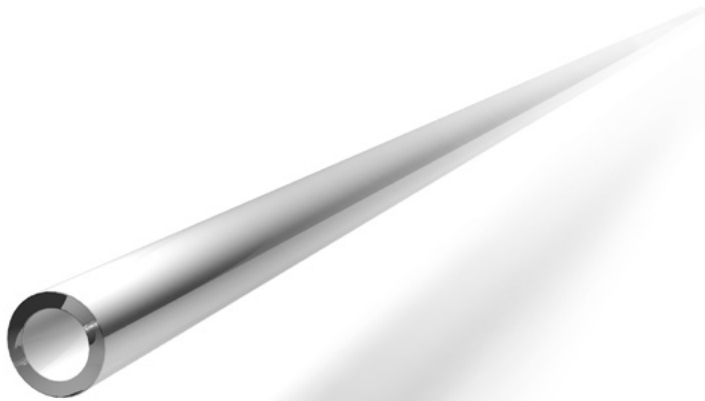

Hollow-core fibers are being used more and more in medical technology – especially in combination with CO₂ and Er:YAG lasers. A visible pilot beam is transmitted – at the same time as invisible IR radiation – via an additional silica layer. The position of the processing beam is thus constantly visible; expensive articulated arms are no longer necessary. This can significantly reduce the costs of the entire medical device.

Hollow-core fibers are biocompatible and sterilizable.

Hollow-Core Fibers for CO₂ Lasers

The JTHWCH fiber is designed for CO₂ wavelengths between 9 μm and 11 μm. The typical attenuation of a 1000 μm ID hollow-core fiber for the CO₂ wavelength 10.6 μm is less than 0.5 dB/m.

Er:YAG Hollow-Core Fibers

The transmission of JTHWEH fibers has been optimized for Er:YAG wavelengths. They are, therefore, frequently used in medical technology.

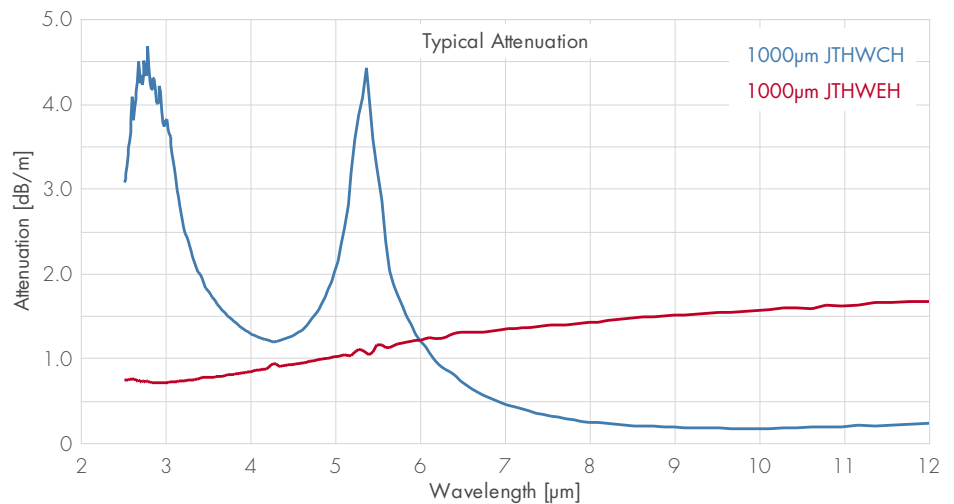

Fiber Coupling



Detailed information is available on our datasheets.
Visit our website!

Fiber Collimators

In fiber technology, a collimated light beam is a crucial prerequisite for both the input and output coupling of light. With the aid of an optical collimator, the divergence of the exiting beam can be significantly reduced. At LASER COMPONENTS, we have therefore developed our own collimator systems, which are produced at our headquarters in Olching.

They are now available in six focal lengths, three housing designs, and with different AR coatings. The primary focus is on single mode fibers, quartz fibers with an NA of 0.22, and hollow-core fibers. These collimators can be mechanically focused and are available for SMA and FC connector systems.

Delivery includes focusing tools.

Special types with different lenses and focal lengths are available upon request.

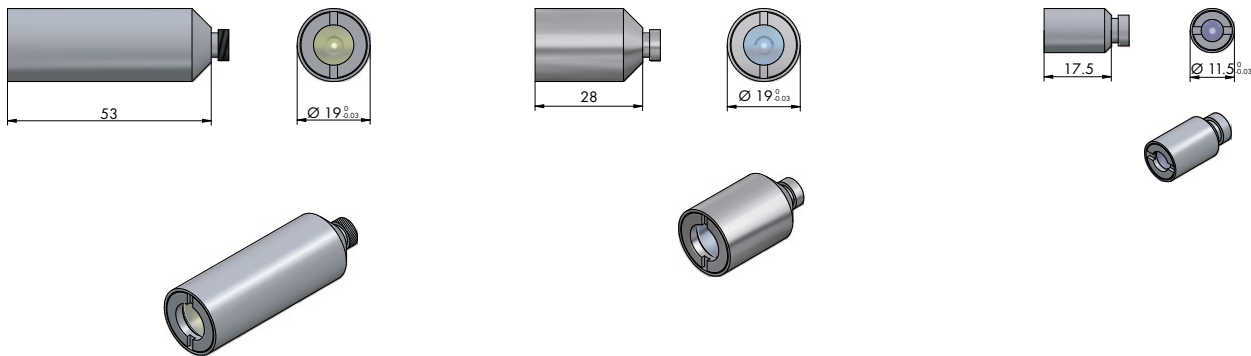

Fiber Collimators

Fiber Types	Single mode 9/125, step index fibers with NA 0.22, hollow-core fibers with 750–1000 μm core diameter
Wavelength Range	VIS/IR and CO_2
Connector System	SMA, FC wide key, FC small key, FC/APC wide key, FC/APC small key (other connectors on request)
Temperature Range [°C]	-40 to +140
Power Efficiency Multimode Fiber	$\geq 85\%$
Power Efficiency CO_2 Fiber	$\geq 90\%$
Available Focus Length [mm]	6.2 / 11 / 15 / 20 / 25.4 / 38.1
Standard Coatings [nm]	350–700, 650–1050, 1050–1600



Fiber Coupling Systems

Fiber coupling systems are used to couple collimated laser beams into an optical fiber. With the adjusting screws, the internal optics can be positioned in such a way that the laser light is focused precisely into the fiber in order to achieve low-loss coupling. The adapter plate of our fiber coupling systems can be adapted to different front panels and laser systems.

Please refer to the datasheet for more detailed information.





FiberKey HP

- Suitable for silica/silica fibers with an NA of 0.22
- **Maximum input coupling power:** < 150W
- **Wavelength:** 400–1300 nm
- **Maximum allowable diameter of the input beam:** 10 mm
- **Optical coating (optional):**
AR1: 400–700 nm
AR2: 633–1064 nm
AR3: 800–1300 nm
- **Optical connection:** SMA



FiberKey C

- Suitable for hollow-core fibers
- **Maximum input coupling power:** approximately 30W
- **Wavelength:** 10.6 μm
- **Maximum allowable diameter of the input beam:** 5 mm
- **Suitable for fiber diameter:** > 750 μm
- **Optical connection:** SMA



FiberKey P

- Suitable for hollow-core fibers
- **Maximum input coupling power:** approximately 30W
- **Wavelength:** 10.6 μm
- **Maximum allowable diameter of the input beam:** 5 mm
- **Suitable for fiber diameter:** > 750 μm
- **Optical connection:** SMA
- Integrated pilot laser beam with a wavelength of 520 nm (other wavelengths available upon request)
- Significantly narrower design than its predecessor model, the FiberKey C

По вопросам продаж и поддержки обращайтесь:

Алматы (7273)495-231
Ангарск (3955)60-70-56
Архангельск (8182)63-90-72
Астрахань (8512)99-46-04
Барнаул (3852)73-04-60
Белгород (4722)40-23-64
Благовещенск (4162)22-76-07
Брянск (4832)59-03-52
Владивосток (423)249-28-31
Владикавказ (8672)28-90-48
Владимир (4922)49-43-18
Волгоград (844)278-03-48
Вологда (8172)26-41-59
Воронеж (473)204-51-73
Екатеринбург (343)384-55-89
Иваново (4932)77-34-06
Ижевск (3412)26-03-58
Иркутск (395)279-98-46
Казань (843)206-01-48

Калининград (4012)72-03-81
Калуга (4842)92-23-67
Кемерово (3842)65-04-62
Киров (8332)68-02-04
Коломна (4966)23-41-49
Кострома (4942)77-07-48
Краснодар (861)203-40-90
Красноярск (391)204-63-61
Курск (4712)77-13-04
Курган (3522)50-90-47
Липецк (4742)52-20-81
Магнитогорск (3519)55-03-13
Москва (495)268-04-70
Мурманск (8152)59-64-93
Набережные Челны (8552)20-53-41
Нижний Новгород (831)429-08-12
Новокузнецк (3843)20-46-81
Ноябрьск (3496)41-32-12
Новосибирск (383)227-86-73

Омск (3812)21-46-40
Орел (4862)44-53-42
Оренбург (3532)37-68-04
Пенза (8412)22-31-16
Петрозаводск (8142)55-98-37
Псков (8112)59-10-37
Пермь (342)205-81-47
Ростов-на-Дону (863)308-18-15
Рязань (4912)46-61-64
Самара (846)206-03-16
Саранск (8342)22-96-24
Санкт-Петербург (812)-309-46-40
Саратов (845)249-38-78
Севастополь (8692)22-31-93
Симферополь (3652)67-13-56
Смоленск (4812)29-41-54
Сочи (862)225-72-31
Ставрополь (8652)20-65-13
Сургут (3462)77-98-35

Сыктывкар (8212)25-95-17
Тамбов (4752)50-40-97
Тверь (4822)63-31-35
Тольятти (8482)63-91-07
Томск (3822)98-41-53
Тула (4872)33-79-87
Тюмень (3452)66-21-18
Ульяновск (8422)24-23-59
Улан-Удэ (3012)59-97-51
Уфа (347)229-48-12
Хабаровск (4212)92-98-04
Чебоксары (8352)28-53-07
Челябинск (351)202-03-61
Череповец (8202)49-02-64
Чита (3022)38-34-83
Якутск (4112)23-90-97
Ярославль (4852)69-52-93

Россия +7(495)268-04-70

Казахстан +7(7172)727-132

Киргизия +996(312)96-26-47

Эл. почта: sao@nt-rt.ru || Сайт: <https://laser.nt-rt.ru>