

Алматы (7273)495-231  
Ангарск (3955)60-70-56  
Архангельск (8182)63-90-72  
Астрахань (8512)99-46-04  
Барнаул (3852)73-04-60  
Белгород (4722)40-23-64  
Благовещенск (4162)22-76-07  
Брянск (4832)59-03-52  
Владивосток (423)249-28-31  
Владикавказ (8672)28-90-48  
Владимир (4922)49-43-18  
Волгоград (844)278-03-48  
Вологда (8172)26-41-59  
Воронеж (473)204-51-73  
Екатеринбург (343)384-55-89  
Иваново (4932)77-34-06  
Ижевск (3412)26-03-58  
Иркутск (395)279-98-46  
Казань (843)206-01-48

Калининград (4012)72-03-81  
Калуга (4842)92-23-67  
Кемерово (3842)65-04-62  
Киров (8332)68-02-04  
Коломна (4966)23-41-49  
Кострома (4942)77-07-48  
Краснодар (861)203-40-90  
Красноярск (391)204-63-61  
Курск (4712)77-13-04  
Курган (3522)50-90-47  
Липецк (4742)52-20-81  
Магнитогорск (3519)55-03-13  
Москва (495)268-04-70  
Мурманск (8152)59-64-93  
Набережные Челны (8552)20-53-41  
Нижний Новгород (831)429-08-12  
Новокузнецк (3843)20-46-81  
Ноябрьск (3496)41-32-12  
Новосибирск (383)227-86-73

Омск (3812)21-46-40  
Орел (4862)44-53-42  
Оренбург (3532)37-68-04  
Пенза (8412)22-31-16  
Петрозаводск (8142)55-98-37  
Псков (8112)59-10-37  
Пермь (342)205-81-47  
Ростов-на-Дону (863)308-18-15  
Рязань (4912)46-61-64  
Самара (846)206-03-16  
Саранск (8342)22-96-24  
Санкт-Петербург (812)-309-46-40  
Саратов (845)249-38-78  
Севастополь (8692)22-31-93  
Симферополь (3652)67-13-56  
Смоленск (4812)29-41-54  
Сочи (862)225-72-31  
Ставрополь (8652)20-65-13  
Сургут (3462)77-98-35

Сыктывкар (8212)25-95-17  
Тамбов (4752)50-40-97  
Тверь (4822)63-31-35  
Тольятти (8482)63-91-07  
Томск (3822)98-41-53  
Тула (4872)33-79-87  
Тюмень (3452)66-21-18  
Ульяновск (8422)24-23-59  
Улан-Удэ (3012)59-97-51  
Уфа (347)229-48-12  
Хабаровск (4212)92-98-04  
Чебоксары (8352)28-53-07  
Челябинск (351)202-03-61  
Череповец (8202)49-02-64  
Чита (3022)38-34-83  
Якутск (4112)23-90-97  
Ярославль (4852)69-52-93

Россия +7(495)268-04-70

Казахстан +7(7172)727-132

Киргизия +996(312)96-26-47

Эл. почта: [sao@nt-rt.ru](mailto:sao@nt-rt.ru) || Сайт: <https://laser.nt-rt.ru>

## High-end IR Components

### IR Components for 5 Hz / 5 $\mu\text{m}$ | 55+ Series

Infrared Components for Slow | 5 Hz and Long | 5  $\mu\text{m}$ + IR-Wavelength Applications

#### Description

This series contains selected emitter and detector versions that are improved state-of the art.

The emitters from Infrasolid have almost ideal emissivity (preferred at 5 Hz) and with the smd package it opens the door to new applications.

The pyroelectric detectors are adjusted to have high dynamic range thus the high emitting power of the thermal IR light source is fully usable. Pyrodetectors with different configurations such as differential, dual or quad are available.

The series is completed by several selected accessories.



#### Components

- **IR-Emitters**  
Power series: HIS2000R-OWC  
SMD series: HIS180smd
- **Pyro Detectors**  
Differential: LD2100, LD2101  
Multi Channel: L2201, L2411
- **Accessories**  
Circuit board for HISpower, HISsmd  
Filter: AR Silicon 2–12  $\mu\text{m}$

#### Target Stories

- Measurements above 5  $\mu\text{m}$  that require slow components
- Improvement of existing applications
- Development of new applications

## IR-Emitters

### Key Features

- Pulsable thermal black-body infrared source
- Patented nanostructured radiating element achieves up to 500% more detection signal!
- Wide wavelength range enables a broad range of applications

### HISpower Series

- Mounted in an industry standard TO-8 package
- Integrated gold plated reflector
- Lower radiating element temperature of 630 °C increases lifetime
- Featured versions:  
HIS2000R-0WC (open version, with Winston cone collimator)

### HISsmd Series

- Mounted in an SMD package with a size of 3 x 3 mm<sup>2</sup>
- Innovative surface technology for customized SMD products
- Enables applications in mobile, portable devices and various wearables
- Featured versions:  
HIS180smd  
HIS180smd array (in progress)



HIS2000R-0WC

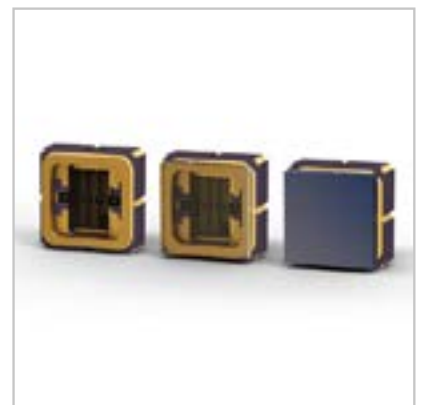

HIS180smd

## HIS2000R-OWC

Thermal infrared emitter with gold plated reflector and Winston cone collimator

Our HIS2000R-OWC is a NiCr filament based thermal emitter in a TO8 package, with a gold plated reflector as well as a gold plated Winston cone collimator. While the reflector directs the radiation emitted from the rear of the filament to the front, the Winston cone collimator bundles and focuses the beam for maximum optical performance. The open emitter offers high power for a wide spectral measuring range.

**HISpower series** emitters have an integrated gold plated reflector that directs the radiation emitted from the rear to the front in order to achieve maximum efficiency. All our emitters offer minimum drift at constant resistance (Ohm). Infrasoilds IR emitters are characterized by a very low temperature coefficient of electrical resistance. Therefore the hot resistance and the cold resistance are almost identical which eases the electrical control of the IR sources.

### Key features

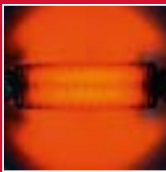

**High radiant power**



**High efficiency**



**Low Cost**

- ✔ Pulsable thermal black-body infrared source mounted in an industry standard TO-8 package.
- ✔ Patented nanostructured radiating element achieves up to 500% more detection signal!
- ✔ Lower radiating element temperature of 630 °C increases lifetime!
- ✔ Wide wavelength range enables a broad range of applications.

*innovative infrared sources for  
 gas detection & spectroscopy*

### Main specifications

Parameter	HIS2000R-OWC
Package	TO-8
Radiating element area	40 mm <sup>2</sup>
Radiating element emissivity	> 0.9
Radiating element temperature	630 °C at 2.5 W
Optical output power	up to 830 mW
Max. electrical power (DC)	2.5 W
Max. electrical voltage	3.8 V
Max. electrical current	660 mA
Electrical resistance	5...6 $\Omega$
Modulation frequency*	4 Hz
Filter/Window	None
Wavelength range	2 to 20 $\mu\text{m}$

\* 50 % modulation depth, square wave signal, 50 % duty cycle

### Optical specifications

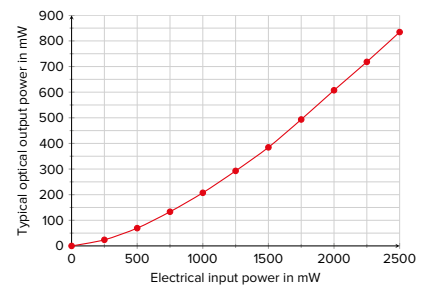
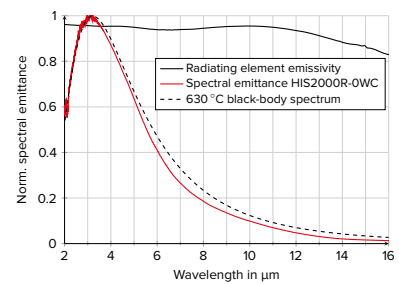

# High-end IR Components

## IR Components for 5 Hz/5 μm | 55+ Series

PRELIMINARY

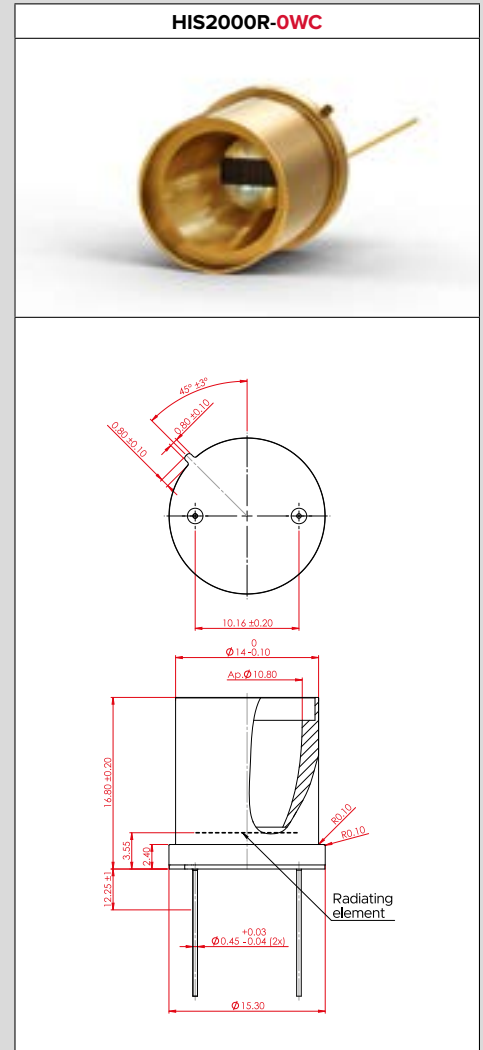
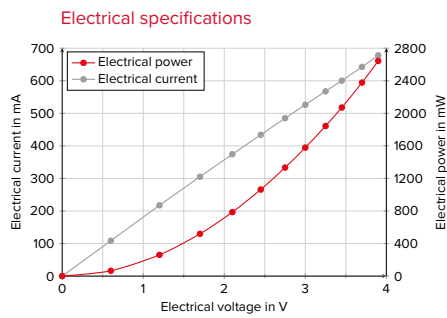
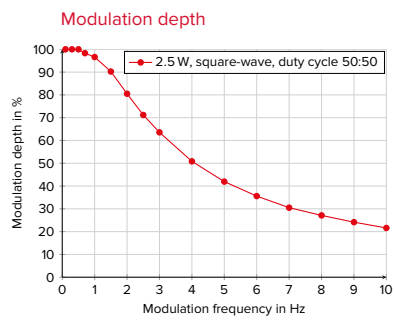
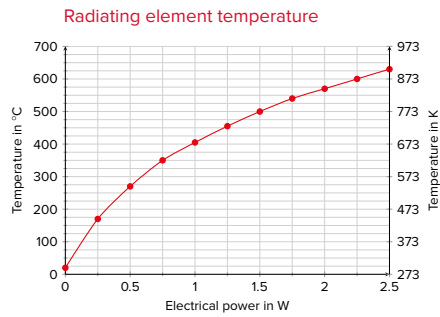

Angular radiation distribution

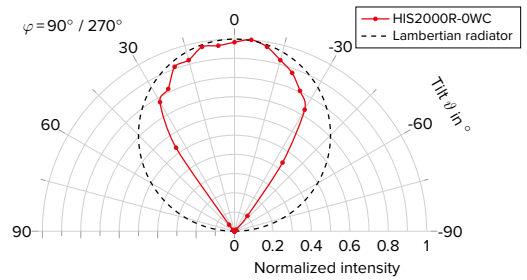
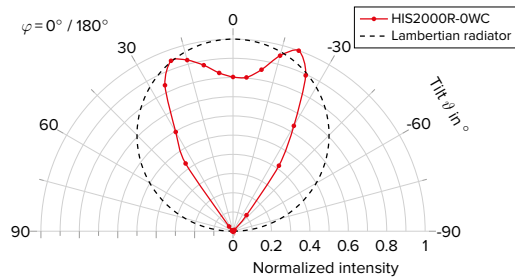
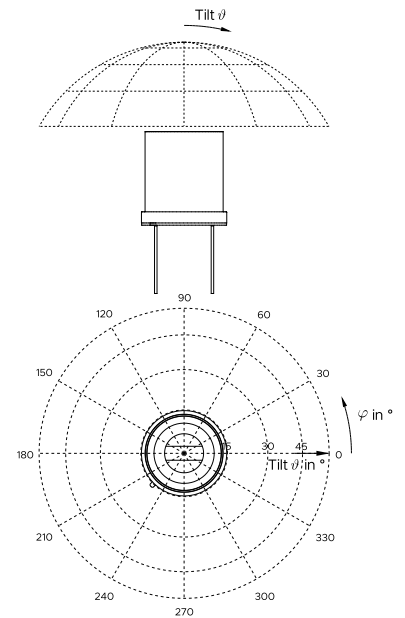
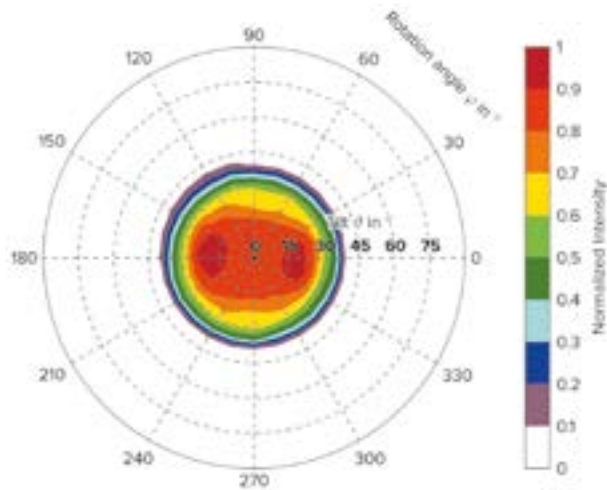

Operating mode recommendation:

All our IR sources can be driven in electrical voltage, current or power regulated mode. The application decides whether the operating mode is DC or AC (pulsed). Depending on the drive mode and the applied electrical power the electrical resistance of the IR emitter can change over time. For highest measurement accuracy a power regulated mode is always recommended for thermal IR emitters. However, it is the most complex operating mode and not suitable in all applications.

For applications that require a small and low-cost driving circuit with a maximum stability we have a technical note with an adjustable low dropout voltage (LDO) regulator.

## HIS180smd

Thermal infrared emitter in standard 3x3 mm<sup>2</sup> SMD, gold plated

**HISsmd series** emitters are small, powerful infrared radiation sources that meet the demands for reliable miniaturized gas sensors and offer a wide range of new application scenarios. The low energy consumption, the high efficiency and the small size allow the use in portable, battery-powered, and mobile applications. These innovative infrared light sources are used, for instance, in respiratory gas analysis, e.g. for the detection of CO<sub>2</sub> and breath alcohol, and in Smart Home and Smartphone applications.

The pioneering SMD package enables a fully automated production in high-volume markets.

Infrasolid's infrared radiation sources are pulsable thermal emitters with a near black-body emittance. Based on a patented nanotechnology and a patented emitter set-up made of a high-melting metal, the free-standing monolithic radiating element and the nanostructured emitter surface offer numerous advantages in many applications.

### Key features



**Very small size**



**High efficiency**

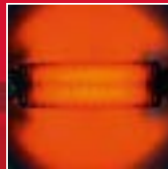

**High radiant power**

- ✔ Pulsable thermal black-body infrared source mounted in a SMD package with a size of 3x3 mm<sup>2</sup>.
- ✔ Patented nanostructured radiating element achieves up to 500% more detection signal!
- ✔ Innovative surface technology for customized SMD products.
- ✔ Wide wavelength range enables applications in mobile, portable devices and various wearables, for miniaturized gas measurement sensors and hand-held spectrometers.

*innovative infrared sources for  
gas detection & spectroscopy*

### Main specifications

Parameter	HIS180smd
Package	SMD3
Radiating element area	1.8 mm <sup>2</sup>
Radiating element emissivity	> 0.9
Radiating element temperature	550 °C at 390 mW
Optical output power	up to 40 mW
Max. electrical power (DC)	390 mW***
Max. electrical voltage	2.8 V***
Max. electrical current	140 mA**
Electrical resistance	19...21 $\Omega$
Modulation frequency*	8 Hz
Filter (glued window)	Si-ARC, Sapphire
Wavelength range	2 to 20 $\mu\text{m}$ **

\* 50 % modulation depth, square wave signal, 50 % duty cycle  
\*\* depending on filter transmissivity  
\*\*\* for open emitters we recommend 2.6 V / 125 mA / 330 mW, which corresponds to an emitter temperature of 500 °C

### Optical specifications

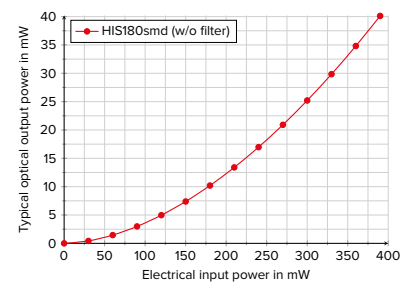
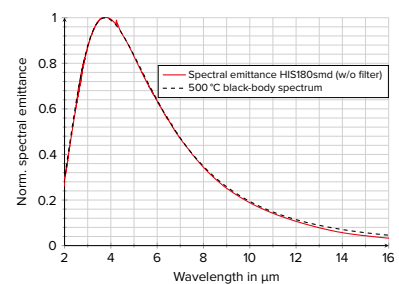

# High-end IR Components

## IR Components for 5 Hz/5 μm | 55+ Series

PRELIMINARY

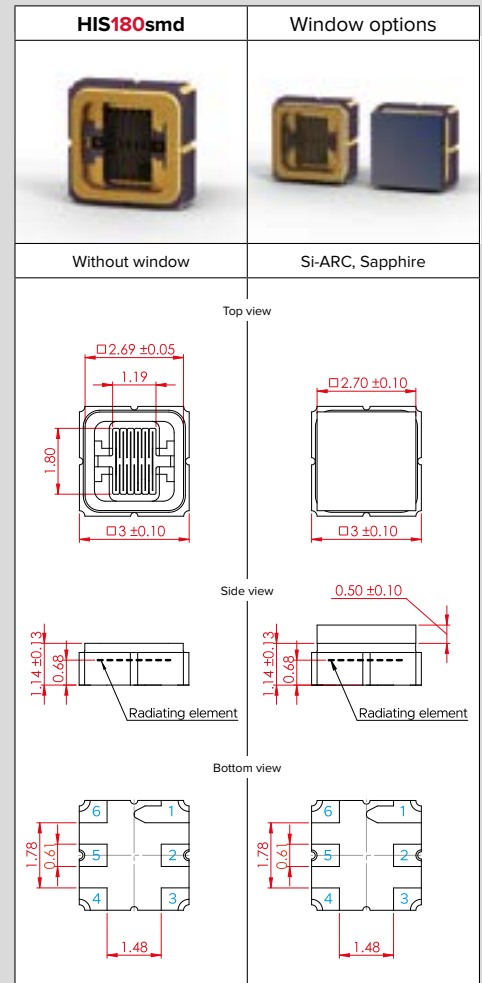
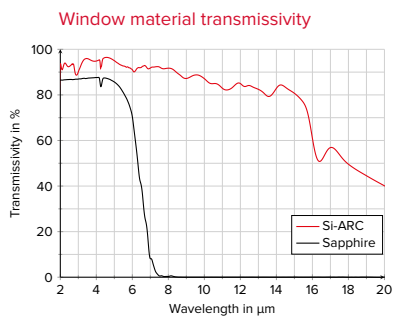
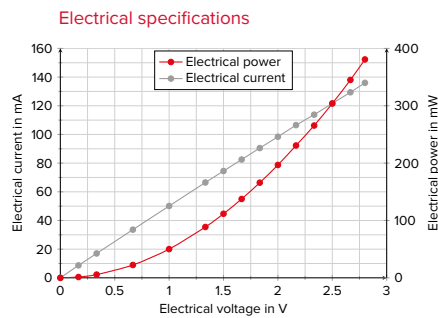
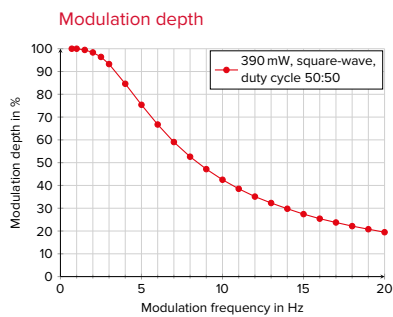
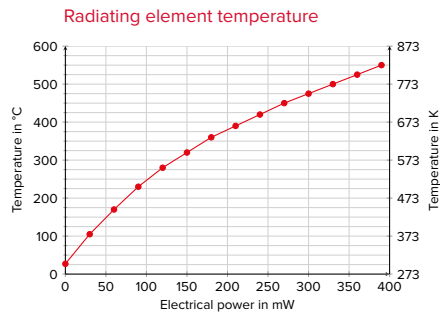

### Connection table

Lead	1	2	3	4	5	6
Connection	Case	Power 1	Case	Case	Power 2	Case

### Ordering information

Type	Infrared window
HIS180smd-0	None
HIS180smd-A	Sapphire
HIS180smd-S	Silicon-ARC

# High-end IR Components

## IR Components for 5 Hz / 5 $\mu\text{m}$ | 55+ Series

PRELIMINARY

Angular radiation distribution (without window)

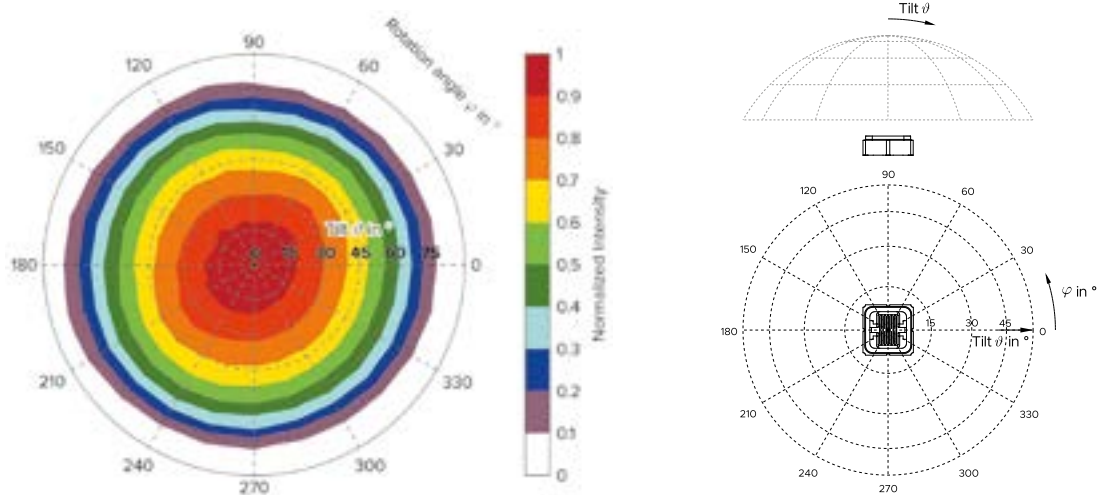

**Breakout board:**

For evaluation purposes we offer a breakout board (BOB) which can be used to easily connect drivers and electronics for evaluation.

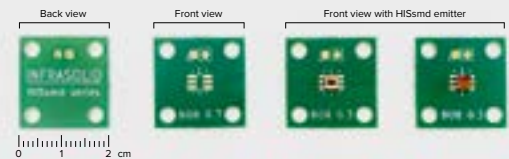

**Operating mode recommendation:**

All our IR sources can be driven in electrical voltage, current or power regulated mode. The application decides whether the operating mode is DC or AC (pulsed). Depending on the drive mode and the applied electrical power the electrical resistance of the IR emitter can change over time. For highest measurement accuracy a power regulated mode is always recommended for thermal IR emitters. However, it is the most complex operating mode and not suitable in all applications.

For applications that require a small and low-cost driving circuit with a maximum stability we have a technical note with an adjustable low dropout voltage (LDO) regulator.



## Pyroelectric Detectors

A pyroelectric detector is an AC thermal infrared detector, that absorbs infrared radiation, transfers it to a temperature change and generates an electrical signal that is proportional to the temperature change.

- Assembled in an ISO:9001 certified facility:  
Laser Components Detector Group, Arizona, USA
- LiTaO<sub>3</sub> and DLaTGS detectors
- Modular design principle
- Wide range of window and filter options

For 55+ series we feature:

### Differential Single Channel Detectors:

- Patented differential scheme
- 44% improvement in SNR over non-differential version
- True differential with differential output for full flexibility and reduction of EMI or common mode rejection and ground noise
- Integrated Op-Amp, single supply

### Multi Channel Detectors:

- Dual and Quad design
- Current mode, with TFC
- Specified @ 5 Hz
- Optimized for high IR emitter radiation

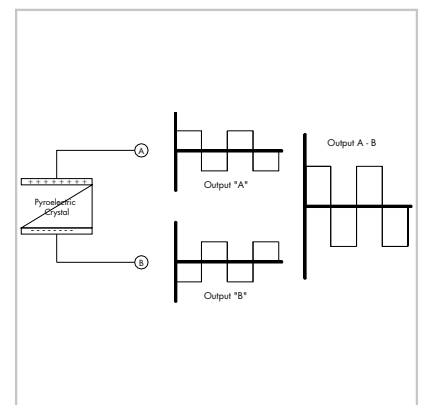

Demonstration of the effect on signal when both outputs are subtracted.

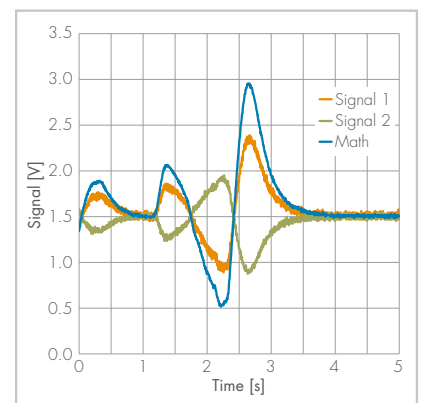

Common mode noise eliminated via differential detector

High-end IR Components  
IR Components for 5 Hz/5  $\mu\text{m}$  | 55+ Series

PRELIMINARY

LD2100X2020

- Single channel LTO Pyroelectric detector
- True differential output
- Current mode
- Single supply
- With TFC

Isometric Drawing

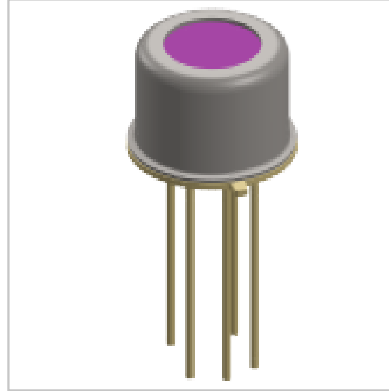

Circuit Diagram

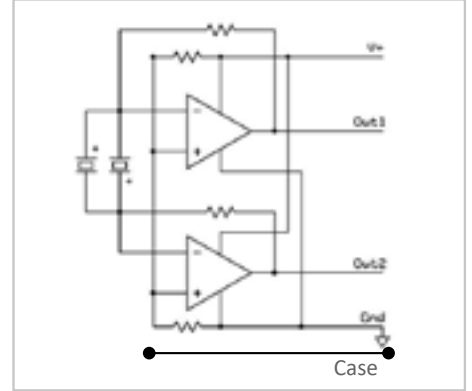

Technical Drawing

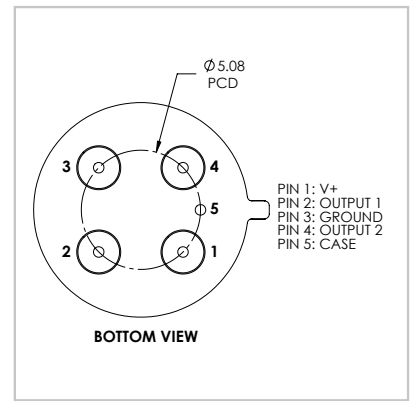
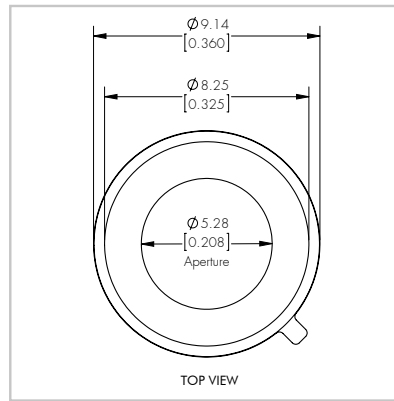
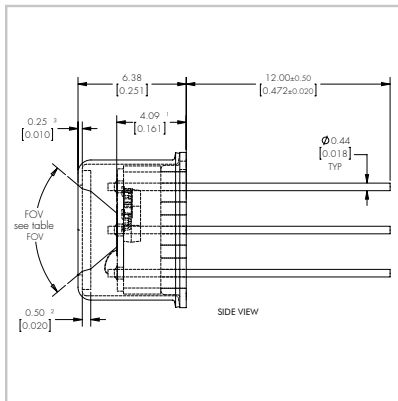

Element Size	Aperture Size*	Package	Absorber
2 mm x 2 mm	Dia. 5.3 mm standard	TO-39 isolated 4 + 1 pin	Organic Black
Feedback Resistor	Amplifier	-3dB Freq [Hz]	Supply
100 GOhm	Op-Amp 5	< 1 Hz – 18 Hz (typical)	2.7 – 10 V (3 V recommended) 1.7 – 2.5 mA
Responsivity [V/W]	D* (Jones) @ 10 Hz **	Noise Density [ $\mu\text{V}/\sqrt{\text{Hz}}$ ]	
Min: 240,000 Typ: 280,000	Min: $5 \times 10^8$ Typ: $8 \times 10^8$	Max: 80	

\* Please refer "Filters and Windows" datasheet for all available options (aperture size depends on filter/window option chosen)

\*\* Without filter/window

# High-end IR Components

## IR Components for 5 Hz / 5 $\mu\text{m}$ | 55+ Series

PRELIMINARY

### LD2101X2020

- Single channel LTO Pyroelectric detector
- True differential output
- Current mode
- Single supply
- With TFC

Isometric Drawing

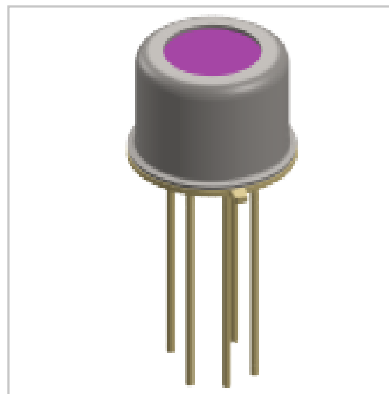

Circuit Diagram

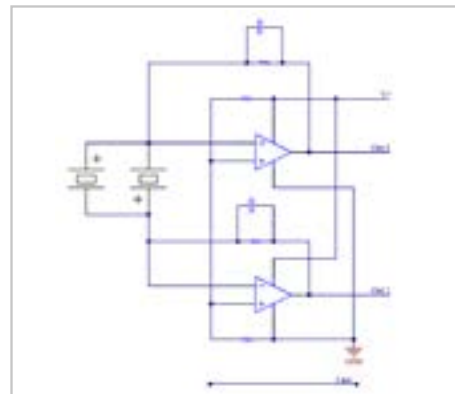

Technical Drawing

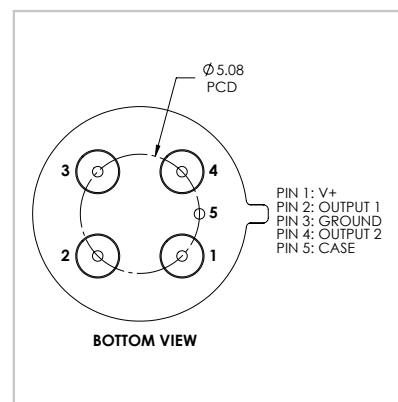
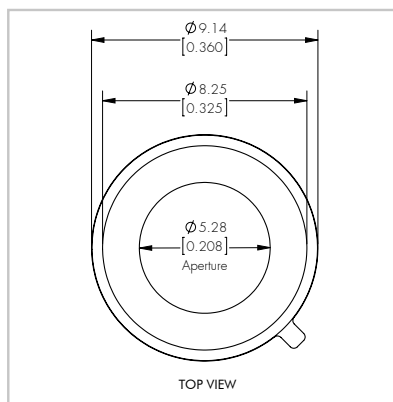
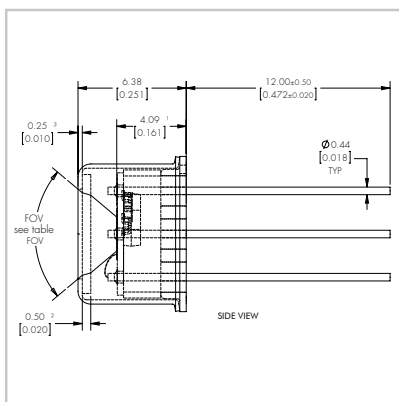

Element Size	Aperture Size*	Package	Absorber
2 mm x 2 mm	Dia. 5.3 mm standard	TO-39 isolated 4 + 1 pin	Organic Black
Feedback Resistor	Amplifier	-3dB Freq [Hz]	Supply
100 GOhm	Op-Amp 5	< 1 Hz – 18 Hz (typical)	2.7 – 10 V (3 V recommended) 1.7 – 2.5 mA
Responsivity [V/W]	D* (Jones) @ 5 Hz **	Noise Density [ $\mu\text{V}/\sqrt{\text{Hz}}$ ]	
Min: 80,000 Typ: 90,000	Min: $6.5 \times 10^8$ Typ: $7.0 \times 10^8$	Max: 25	

\* Please refer "Filters and Windows" datasheet for all available options (aperture size depends on filter/window option chosen)

\*\* Without filter/window

High-end IR Components  
IR Components for 5 Hz/5  $\mu\text{m}$  | 55+ Series

PRELIMINARY

L2201D1810

- Dual channel Pyroelectric detector
- Current mode
- Single supply
- With TFC

Isometric Drawing

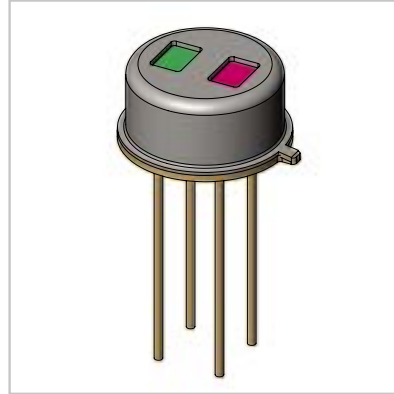

Circuit Diagram

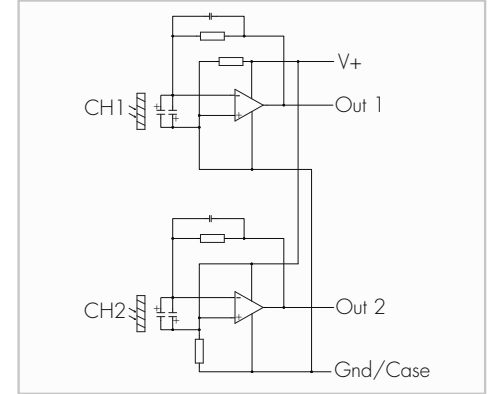

Technical Drawing

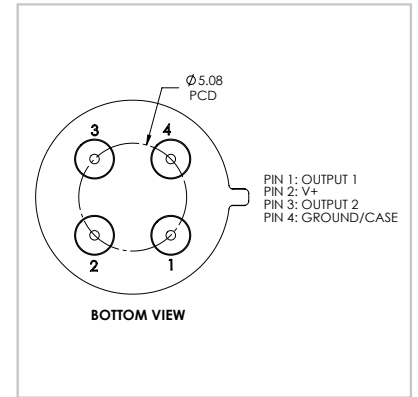
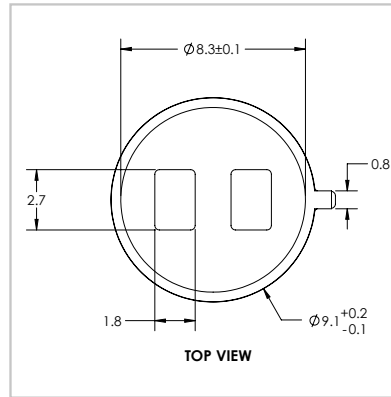
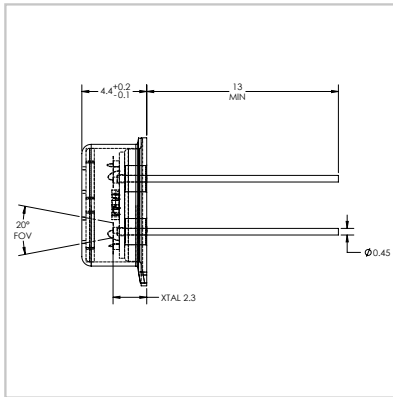

Element Size	Aperture Size*	Package	Absorber
1.8 mm x 1.0 mm	2.7 mm x 1.8 mm	TO-39 4-pin	Organic Black
Feedback Resistor	Amplifier	-3dB Freq [Hz]	Supply Voltage [V]
100 GOhm	Op-Amp 7	TBD	1.8 - 5.5 V (3 V recommended)
Responsivity [V/W]**	D* [Jones]** @ 5 Hz	Noise Density [ $\mu\text{V}/\sqrt{\text{Hz}}$ ]	Output Polarity
Min: 30,000 Typ: 34,000	Min: $3 \times 10^8$ Typ: $5 \times 10^8$	Max: 13 $\mu\text{V}$	Negative

\* Please refer "Filters and Windows" datasheet for all available options.

\*\* Without filter / window

# High-end IR Components

## IR Components for 5 Hz / 5 $\mu\text{m}$ | 55+ Series

PRELIMINARY

### L2411D2020

- Quad channel Pyroelectric detector
- Current mode
- Dual supply
- With TFC

Isometric Drawing

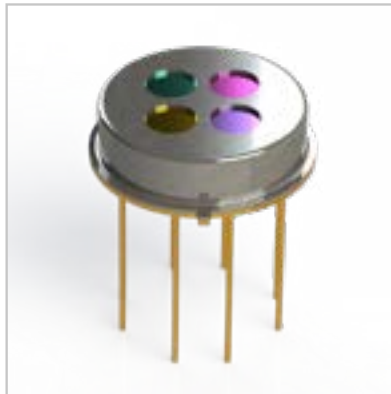

Circuit Diagram

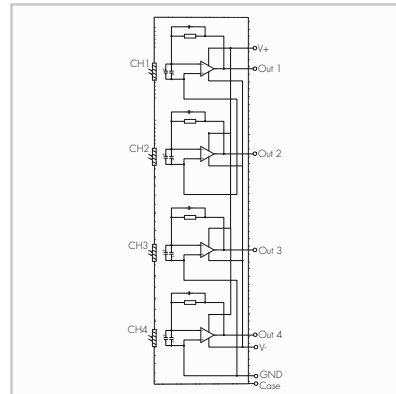

Technical Drawing

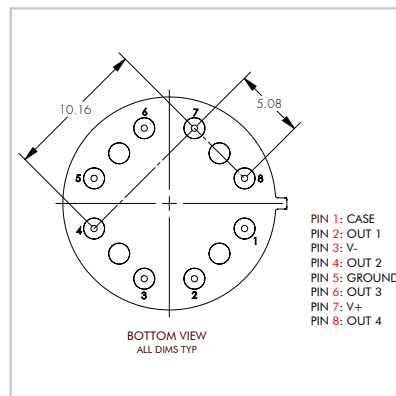
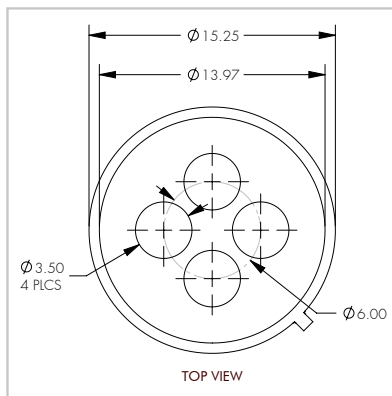
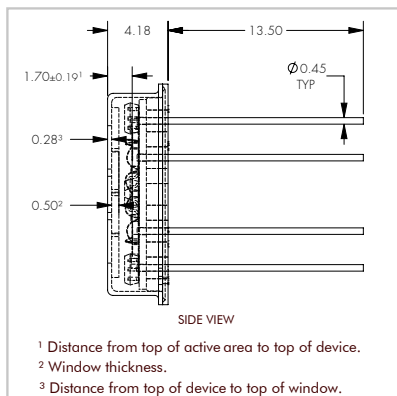

Element Size	Aperture Size*	Package	Absorber
2.0 mm x 2.0 mm	dia. 3.5 mm	TO-8	Organic Black
Feedback Resistor	Amplifier	-3dB Freq [Hz]	Supply Voltage [V]
100 GOhm	Op-Amp 7	TBD	Dual Supply $\pm 0.9 - \pm 2.75$ V ( $\pm 2.5$ V recommended)
Responsivity [V/W]**	D* [Jones]** @ 5 Hz	Noise Density [ $\mu\text{V}/\sqrt{\text{Hz}}$ ]	Output Polarity
Min: 40,000 Typ: 45,000	Min: $5 \times 10^8$ Typ: $6 \times 10^8$	Max: 14 $\mu\text{V}$	Negative

\* Please refer "Filters and Windows" datasheet for all available options

\*\* Without filter / window

## Accessories

### Driving Circuit Board

For a quick evaluation of HISpower series IR emitters we offer a simple driving circuit board.

Also for smd series a breakout board (BOB) is available which can be used to easy connect drivers and electronics for evaluation.

Please contact us for further technical details and ordering information.

### Filter

Si window with High Efficient Broadband AR-coating

For applications in the 1 – 12  $\mu\text{m}$  wavelength range, several filter and window materials for pyroelectrics are useable. They are described in the filter and window datasheet.

One optimized version is a broadband silicon window with the following specification:

$T_{\text{avg}} (1.55 \mu\text{m}) > 40\%$  (both sides, best effort)

$T_{\text{avg}} (2.0 - 12 \mu\text{m}) \geq 87\%$  (both sides)

$T_{\text{abs}} (2.0 - 12 \mu\text{m}) \geq 75\%$  (both sides)

One dip with  $T_{\text{abs}} > 70\%$  @ 2 – 4  $\mu\text{m}$  allowed,  
 if  $T > 92\%$  @ 8 – 10  $\mu\text{m}$ .



Driving circuit board for a quick evaluation of HISpower series IR emitters.

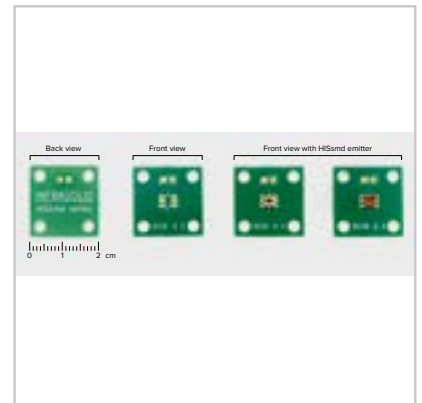

Breakout board for HISsmd series.

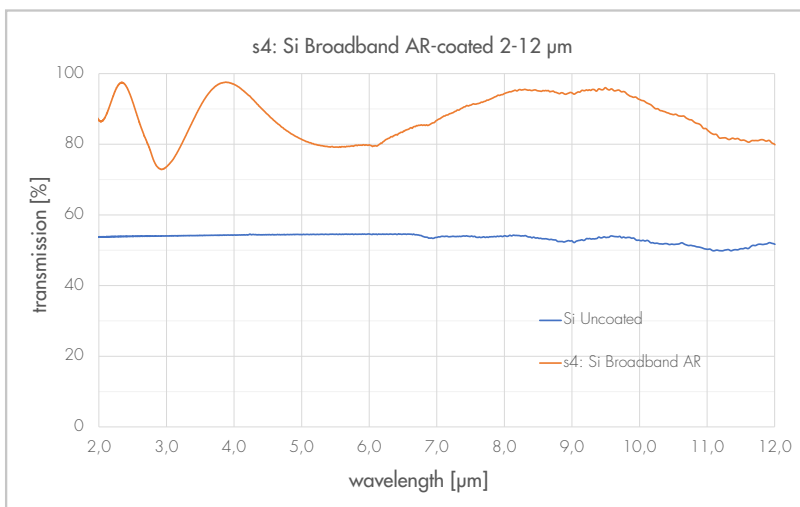

## Absolute Maximum Ratings for pyroelectric LTO detectors

	Min	Max
Storage temperature [°C]	- 25	+ 60 **
Operating temperature [°C]	- 20	+ 85
Soldering temperature, 5 sec [°C]	+ 280	+ 300
ESD damage threshold, Human Body Model Class ...* [V]	0	< 250

\* ANSI/ESD STN5. 1-2007

\*\* Limited by packing materials.

### Handling

ESD sensitive device. High electrostatic discharge can damage or degrade the device. Use proper ESD handling precautions.

## Part Number Designation

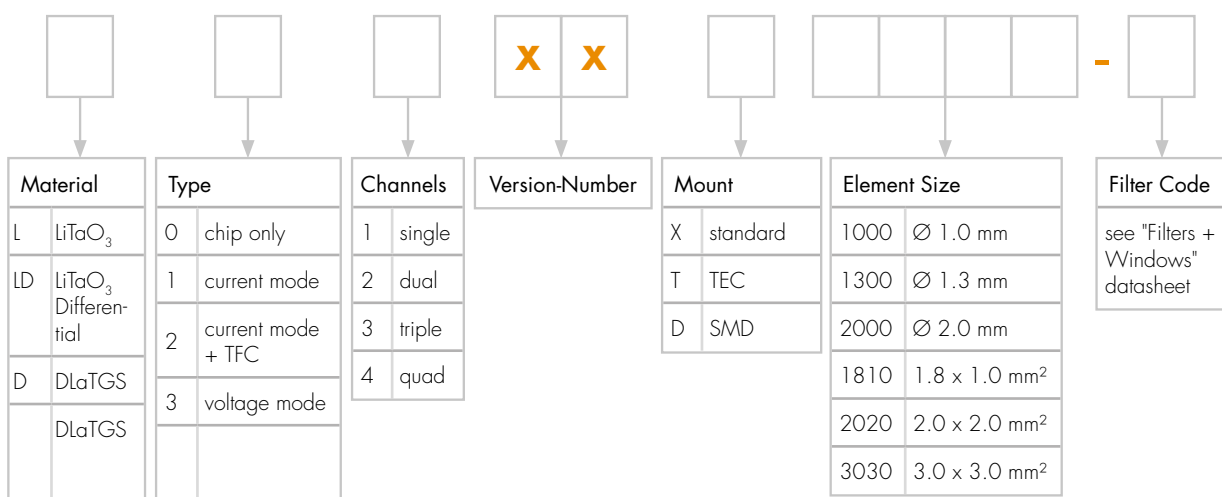

## По вопросам продаж и продукции обращайтесь:

Алматы (7273)495-231  
Ангарск (3955)60-70-56  
Архангельск (8182)63-90-72  
Астрахань (8512)99-46-04  
Барнаул (3852)73-04-60  
Белгород (4722)40-23-64  
Благовещенск (4162)22-76-07  
Брянск (4832)59-03-52  
Владивосток (423)249-28-31  
Владикавказ (8672)28-90-48  
Владимир (4922)49-43-18  
Волгоград (844)278-03-48  
Вологда (8172)26-41-59  
Воронеж (473)204-51-73  
Екатеринбург (343)384-55-89  
Иваново (4932)77-34-06  
Ижевск (3412)26-03-58  
Иркутск (395)279-98-46  
Казань (843)206-01-48

Калининград (4012)72-03-81  
Калуга (4842)92-23-67  
Кемерово (3842)65-04-62  
Киров (8332)68-02-04  
Коломна (4966)23-41-49  
Кострома (4942)77-07-48  
Краснодар (861)203-40-90  
Красноярск (391)204-63-61  
Курск (4712)77-13-04  
Курган (3522)50-90-47  
Липецк (4742)52-20-81  
Магнитогорск (3519)55-03-13  
Москва (495)268-04-70  
Мурманск (8152)59-64-93  
Набережные Челны (8552)20-53-41  
Нижегород (831)429-08-12  
Новокузнецк (3843)20-46-81  
Новый Уренгой (3496)41-32-12  
Новосибирск (383)227-86-73

Омск (3812)21-46-40  
Орел (4862)44-53-42  
Оренбург (3532)37-68-04  
Пенза (8412)22-31-16  
Петрозаводск (8142)55-98-37  
Псков (8112)59-10-37  
Пермь (342)205-81-47  
Ростов-на-Дону (863)308-18-15  
Рязань (4912)46-61-64  
Самара (846)206-03-16  
Саранск (8342)22-96-24  
Санкт-Петербург (812)-309-46-40  
Саратов (845)249-38-78  
Севастополь (8692)22-31-93  
Симферополь (3652)67-13-56  
Смоленск (4812)29-41-54  
Сочи (862)225-72-31  
Ставрополь (8652)20-65-13  
Сургут (3462)77-98-35

Сыктывкар (8212)25-95-17  
Тамбов (4752)50-40-97  
Тверь (4822)63-31-35  
Тольятти (8482)63-91-07  
Томск (3822)98-41-53  
Тула (4872)33-79-87  
Тюмень (3452)66-21-18  
Ульяновск (8422)24-23-59  
Улан-Удэ (3012)59-97-51  
Уфа (347)229-48-12  
Хабаровск (4212)92-98-04  
Чебоксары (8352)28-53-07  
Челябинск (351)202-03-61  
Череповец (8202)49-02-64  
Чита (3022)38-34-83  
Якутск (4112)23-90-97  
Ярославль (4852)69-52-93

Россия +7(495)268-04-70

Казахстан +7(7172)727-132

Киргизия +996(312)96-26-47