

Алматы (7273)495-231  
Ангарск (3955)60-70-56  
Архангельск (8182)63-90-72  
Астрахань (8512)99-46-04  
Барнаул (3852)73-04-60  
Белгород (4722)40-23-64  
Благовещенск (4162)22-76-07  
Брянск (4832)59-03-52  
Владивосток (423)249-28-31  
Владикавказ (8672)28-90-48  
Владимир (4922)49-43-18  
Волгоград (844)278-03-48  
Вологда (8172)26-41-59  
Воронеж (473)204-51-73  
Екатеринбург (343)384-55-89  
Иваново (4932)77-34-06  
Ижевск (3412)26-03-58  
Иркутск (395)279-98-46  
Казань (843)206-01-48

Калининград (4012)72-03-81  
Калуга (4842)92-23-67  
Кемерово (3842)65-04-62  
Киров (8332)68-02-04  
Коломна (4966)23-41-49  
Кострома (4942)77-07-48  
Краснодар (861)203-40-90  
Красноярск (391)204-63-61  
Курск (4712)77-13-04  
Курган (3522)50-90-47  
Липецк (4742)52-20-81  
Магнитогорск (3519)55-03-13  
Москва (495)268-04-70  
Мурманск (8152)59-64-93  
Набережные Челны (8552)20-53-41  
Нижний Новгород (831)429-08-12  
Новокузнецк (3843)20-46-81  
Ноябрьск (3496)41-32-12  
Новосибирск (383)227-86-73

Омск (3812)21-46-40  
Орел (4862)44-53-42  
Оренбург (3532)37-68-04  
Пенза (8412)22-31-16  
Петрозаводск (8142)55-98-37  
Псков (8112)59-10-37  
Пермь (342)205-81-47  
Ростов-на-Дону (863)308-18-15  
Рязань (4912)46-61-64  
Самара (846)206-03-16  
Саранск (8342)22-96-24  
Санкт-Петербург (812)-309-46-40  
Саратов (845)249-38-78  
Севастополь (8692)22-31-93  
Симферополь (3652)67-13-56  
Смоленск (4812)29-41-54  
Сочи (862)225-72-31  
Ставрополь (8652)20-65-13  
Сургут (3462)77-98-35

Сыктывкар (8212)25-95-17  
Тамбов (4752)50-40-97  
Тверь (4822)63-31-35  
Тольятти (8482)63-91-07  
Томск (3822)98-41-53  
Тула (4872)33-79-87  
Тюмень (3452)66-21-18  
Ульяновск (8422)24-23-59  
Улан-Удэ (3012)59-97-51  
Уфа (347)229-48-12  
Хабаровск (4212)92-98-04  
Чебоксары (8352)28-53-07  
Челябинск (351)202-03-61  
Череповец (8202)49-02-64  
Чита (3022)38-34-83  
Якутск (4112)23-90-97  
Ярославль (4852)69-52-93

Россия +7(495)268-04-70

Казахстан +7(7172)727-132

Киргизия +996(312)96-26-47

Эл. почта: [sao@nt-rt.ru](mailto:sao@nt-rt.ru) || Сайт: <https://laser.nt-rt.ru>

## A-CUBE-Series High Sensitivity APD Detector Modules

### Description

Laser Components' new A-CUBE range of APD modules has been designed for customers interested in experimenting with APDs. Featuring a low-noise silicon (or InGaAs) APD with matched preamplifier and integrated high voltage supply, the module offers everything needed to operate APDs easily and conveniently. In-built temperature compensation circuitry allows the APD to be operated at constant gain even if the ambient temperature changes. A  $\pm 12$  V DC supply is all that is needed to operate the module.

The optional FC connector provides a convenient method for connecting the detector to the sample using an optical fiber.

Custom designed modules and OEM versions are available on request.



### Features

- High sensitivity
- Low noise
- Easy handling
- Compact
- RS-232 interface
- Fiber coupling (optional)

### Applications

- APD evaluation
- Range finding / LIDAR
- Optical communication systems
- Spectroscopy
- Fluorescence
- Medical

## Si-APD Modules

### Generic Characteristics @ T = 25 °C

	Min.	Typ.	Max.	Units
Wavelength range	400		1100	nm
Peak sensitivity		905		nm

### Absolute Maximum Ratings

	Min.	Typ.	Max.	Units
Supply voltage	±10	±12	±15	V
Operating temperature	0		+50	°C
Storage temperature	-20		+70	°C
Output voltage				
A-CUBE-S500-01/-03/-10/-25/-240				
A-CUBE-S1500-01/-03/-10/-25				
A-CUBE-S3000-01/-03/-10/-25				
(50 Ω) (typical)		+1.5		V
(1 MΩ) (typical)		+3		V
A-CUBE-S500-100				
(50 Ω) (typical)		-1.5		V
(1 MΩ) (typical)		-3		V

Fig. 1: Spectral Response @ M = 100

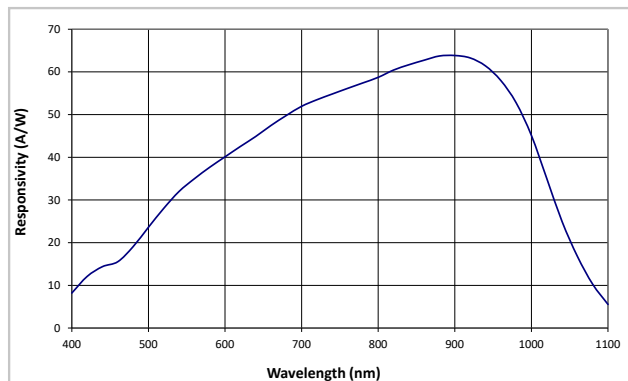

# A-CUBE-Series High Sensitivity APD Detector Modules

## Technical Specifications for 0.5 mm A-CUBE (typical values @ M = 100, 25 °C)

Part Number	A-CUBE-S500-01	A-CUBE-S500-03	A-CUBE-S500-10	A-CUBE-S500-25	A-CUBE-S500-100	A-CUBE-S500-240	Units
Si-APD	SAR500	SAR500	SAR500	SAR500	SAR500	SAR500	
Active area diameter	0.5	0.5	0.5	0.5	0.5	0.5	mm
Wavelength range	400 - 1000	400 - 1000	400 - 1000	400 - 1000	400 - 1000	400 - 1000	nm
Peak sensitivity	905	905	905	905	905	905	nm
Bandwidth	DC - 1	DC - 3	DC - 10	DC - 25	0.01 - 100	0.01 - 240	MHz
Responsivity							
540 nm	270	27	2.7	0.27	15.0	5.4	MV/W
650 nm	400	40	4	0.4	22.0	8.0	MV/W
905 nm	500	50	5	0.5	27.0	10.0	MV/W
NEP							
540 nm	11	11	55	150	70	75	fW/rtHz
650 nm	7.5	7.5	37.5	100	45	50	fW/rtHz
905 nm	6	6	30	80	40	40	fW/rtHz
Output noise density	3000	300	150	40	1000	400	nV/rtHz
Input referred noise density (maximum)	0.3	0.3	1.5	4	2	2	pA/rtHz

Note: Noise measured at 100 kHz.

Fig. 2: Spectral Response @ M = 100

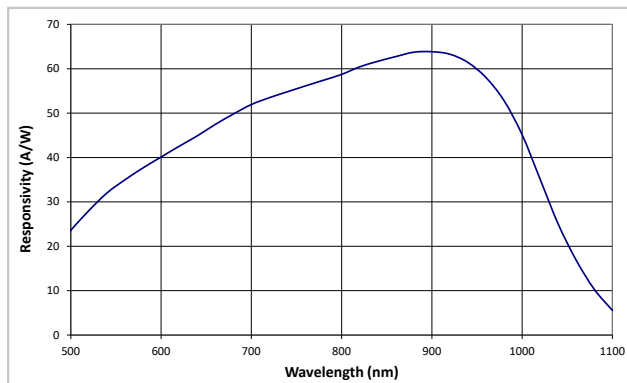

## A-CUBE-Series High Sensitivity APD Detector Modules

### Technical Specifications for 1.5 mm A-CUBE (typical values @ M = 100, 25 °C)

Part Number	A-CUBE-S1500-01	A-CUBE-S1500-03	A-CUBE-S1500-10	A-CUBE-S1500-25	Units
Si-APD	SAR1500	SAR1500	SAR1500	SAR1500	
Diameter	1.5	1.5	1.5	1.5	mm
Wavelength range	400 - 1000	400 - 1000	400 - 1000	400 - 1000	nm
Peak sensitivity	905	905	905	905	nm
Bandwidth *	DC - 1	DC - 3	DC - 10	DC - 25	MHz
Responsivity					
540 nm	270	27	2.7	0.27	MV/W
650 nm	400	40	4	0.4	MV/W
905 nm	500	50	5	0.5	MV/W
NEP					
540 nm	11	37	55	150	fW/rHz
650 nm	7.5	25	37.5	100	fW/rHz
905 nm	6	20	30	80	fW/rHz
Output noise density	3000	1000	150	40	nV/rHz
Input referred noise density (maximum)	0.3	1	1.5	4	pA/rHz

Note: Noise measured at 100 kHz.

A-CUBE1500-01 and A-CUBE1500-03 will saturate with high background light levels due to their very high sensitivity.

Operation in environments with high background levels (e.g. daylight) is therefore not recommended.

\* Custom versions up to 240 MHz are available on request.

### Technical Specifications for 3 mm A-CUBE (typical values @ M = 100, 25 °C)

Part Number	A-CUBE-S3000-01	A-CUBE-S3000-03	A-CUBE-S3000-10	A-CUBE-S3000-25	Units
Si-APD	SAR3000	SAR3000	SAR3000	SAR3000	
Diameter	3	3	3	3	mm
Wavelength range	400 - 1000	400 - 1000	400 - 1000	400 - 1000	nm
Peak sensitivity	905	905	905	905	nm
Bandwidth	DC - 1	DC - 3	DC - 10	DC - 25	MHz
Responsivity					
540 nm	270	27	2.7	0.27	MV/W
650 nm	400	40	4	0.4	MV/W
905 nm	500	50	5	0.5	MV/W
NEP					
540 nm	15	37	55	225	fW/rHz
650 nm	11	25	38	150	fW/rHz
905 nm	9	20	30	120	fW/rHz
Output noise density	4000	1000	150	60	nV/rHz
Input referred noise density (maximum)	0.4	1	1.5	6	pA/rHz

Note: Noise measured at 100 kHz.

A-CUBE3000-01 and A-CUBE3000-03 will saturate with high background light levels due to their very high sensitivity.

Operation in environments with high background levels (e.g. daylight) is therefore not recommended.

## InGaAs-APD Modules

### Generic Characteristics @ T = 25 °C

	Min.	Typ.	Max.	Units
Wavelength range	1000		1700	nm
Peak sensitivity		1550		nm

### Absolute Maximum Ratings

	Min.	Typ.	Max.	Units
Supply voltage	±10	±12	±15	V
Operating temperature	0		+50	°C
Storage temperature	-20		+70	°C
Output voltage				
A-CUBE-I200-01/-03/-10/-25/-240				
(50 Ω) (typical)			+1.6	V
(1 MΩ) (typical)			+2.5	V
A-CUBE-I200-100				
(50 Ω) (typical)			-1.6	V
(1 MΩ) (typical)			-2.5	V

Fig. 3: Spectral Response and Quantum Efficiency (M = 10 @ 1550 nm)

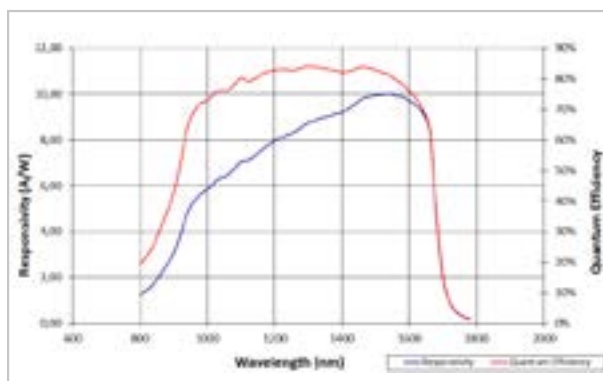

# A-CUBE-Series

## High Sensitivity APD Detector Modules

### Technical Specifications for 200 $\mu\text{m}$ A-CUBE-Module (typical values @ $M = 10, 25^\circ\text{C}$ )

Part Number	A-CUBE-I200-01	A-CUBE-I200-03	A-CUBE-I200-10	A-CUBE-I200-25	A-CUBE-I200-100	A-CUBE-I200-240	Units
InGaAs-APD	IAG200	IAG200	IAG200	IAG200	IAG200	IAG200	
Diameter	200	200	200	200	200	200	$\mu\text{m}$
Wavelength range	900 - 1700	900 - 1700	900 - 1700	900 - 1700	900 - 1700	900 - 1700	nm
Peak sensitivity	1550	1550	1550	1550	1550	1550	nm
Bandwidth	DC - 1	DC - 3	DC - 10	DC - 25	0.01 - 100	0.01 - 240	MHz
Responsivity 1550 nm	94	9.4	0.94	0.094	0.50	0.19	MV/W
NEP 1550 nm	32	64	160	425	200	300	fW/rtHz
Output noise density	3000	600	150	40	1000	500	nV/rtHz
Input referred noise density (maximum)	0.3	0.6	1.5	4	2	3	pA/rtHz

Note: Noise measured at 100 kHz.

### Product Number Designations

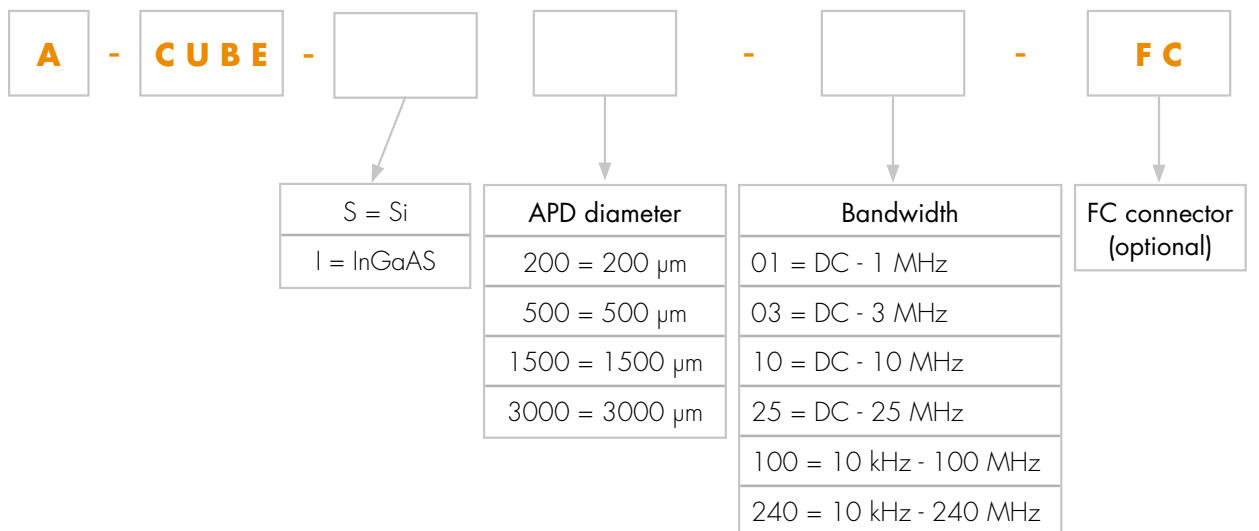

A-CUBE-Series  
High Sensitivity APD Detector Modules

Package Drawings

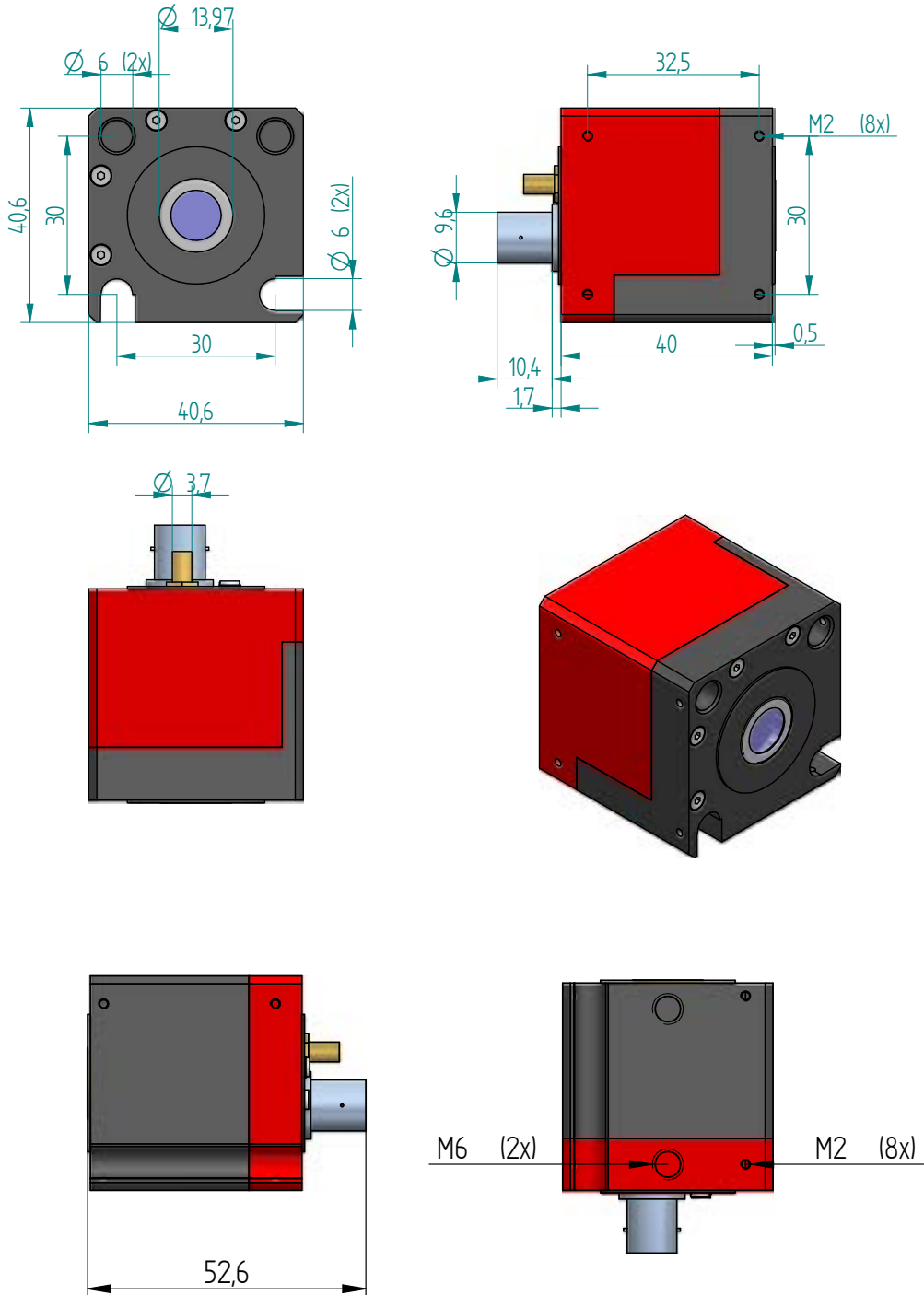

Dimensions in [mm]

## PIN Configuration

P1 HV bias voltage adjustment

P2  $R_{TK}$  temperature compensation adjustment

M9	1	GND	
	2	+ $V_{op}$	Operating voltage +12 V/300 mA
	3	R x D	Receive input (RS 232)
	4	- $V_{op}$	Operating voltage -12 V/300 mA
	5	T x D	Transmit output (RS 232)

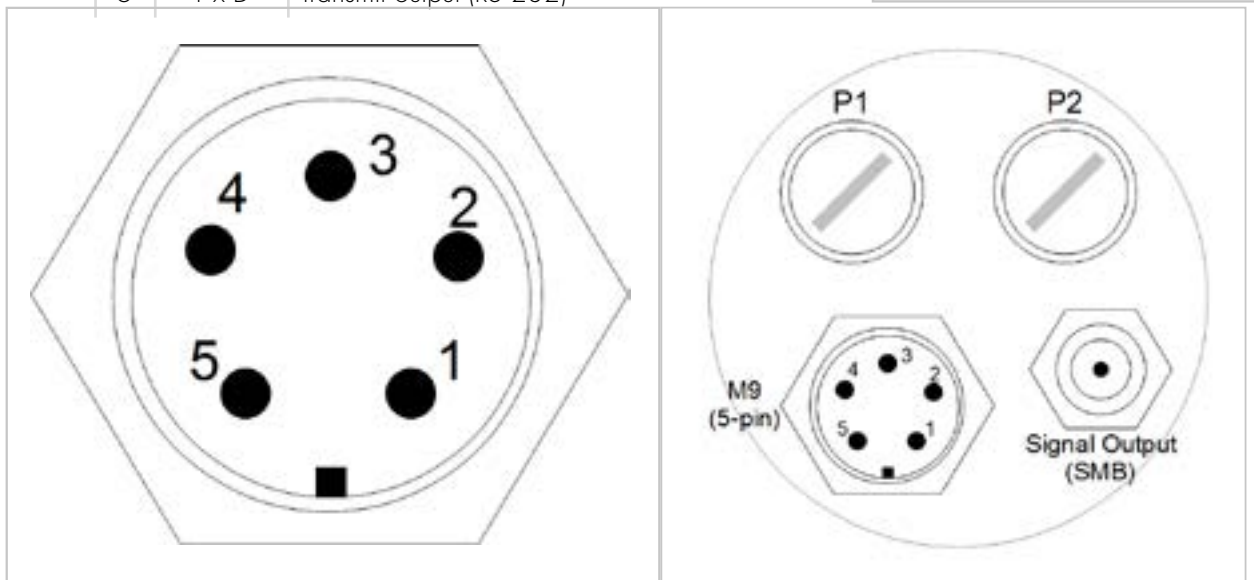
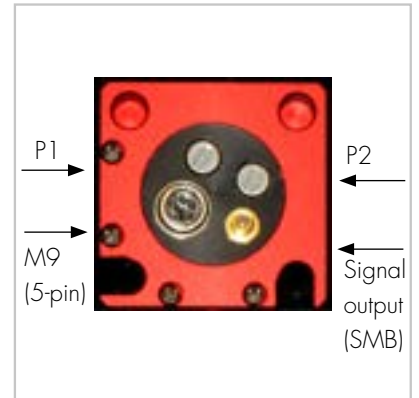

**По вопросам продаж и продукции обращайтесь:**

Алматы (7273)495-231  
Ангарск (3955)60-70-56  
Архангельск (8182)63-90-72  
Астрахань (8512)99-46-04  
Барнаул (3852)73-04-60  
Белгород (4722)40-23-64  
Благовещенск (4162)22-76-07  
Брянск (4832)59-03-52  
Владивосток (423)249-28-31  
Владикавказ (8672)28-90-48  
Владимир (4922)49-43-18  
Волгоград (844)278-03-48  
Вологда (8172)26-41-59  
Воронеж (473)204-51-73  
Екатеринбург (343)384-55-89  
Иваново (4932)77-34-06  
Ижевск (3412)26-03-58  
Иркутск (395)279-98-46  
Казань (843)206-01-48

Калининград (4012)72-03-81  
Калуга (4842)92-23-67  
Кемерово (3842)65-04-62  
Киров (8332)68-02-04  
Коломна (4966)23-41-49  
Кострома (4942)77-07-48  
Краснодар (861)203-40-90  
Красноярск (391)204-63-61  
Курск (4712)77-13-04  
Курган (3522)50-90-47  
Липецк (4742)52-20-81  
Магнитогорск (3519)55-03-13  
Москва (495)268-04-70  
Мурманск (8152)59-64-93  
Набережные Челны (8552)20-53-41  
Нижний Новгород (831)429-08-12  
Новокузнецк (3843)20-46-81  
Ноябрьск (3496)41-32-12  
Новосибирск (383)227-86-73

Омск (3812)21-46-40  
Орел (4862)44-53-42  
Оренбург (3532)37-68-04  
Пенза (8412)22-31-16  
Петрозаводск (8142)55-98-37  
Псков (8112)59-10-37  
Пермь (342)205-81-47  
Ростов-на-Дону (863)308-18-15  
Рязань (4912)46-61-64  
Самара (846)206-03-16  
Саранск (8342)22-96-24  
Санкт-Петербург (812)-309-46-40  
Саратов (845)249-38-78  
Севастополь (8692)22-31-93  
Симферополь (3652)67-13-56  
Смоленск (4812)29-41-54  
Сочи (862)225-72-31  
Ставрополь (8652)20-65-13  
Сургут (3462)77-98-35

Сыктывкар (8212)25-95-17  
Тамбов (4752)50-40-97  
Тверь (4822)63-31-35  
Тольятти (8482)63-91-07  
Томск (3822)98-41-53  
Тула (4872)33-79-87  
Тюмень (3452)66-21-18  
Ульяновск (8422)24-23-59  
Улан-Удэ (3012)59-97-51  
Уфа (347)229-48-12  
Хабаровск (4212)92-98-04  
Чебоксары (8352)28-53-07  
Челябинск (351)202-03-61  
Череповец (8202)49-02-64  
Чита (3022)38-34-83  
Якутск (4112)23-90-97  
Ярославль (4852)69-52-93

Россия +7(495)268-04-70

Казахстан +7(7172)727-132

Киргизия +996(312)96-26-47

Эл. почта: [sao@nt-rt.ru](mailto:sao@nt-rt.ru) || Сайт: <https://laser.nt-rt.ru>