

Алматы (7273)495-231
Ангарск (3955)60-70-56
Архангельск (8182)63-90-72
Астрахань (8512)99-46-04
Барнаул (3852)73-04-60
Белгород (4722)40-23-64
Благовещенск (4162)22-76-07
Брянск (4832)59-03-52
Владивосток (423)249-28-31
Владикавказ (8672)28-90-48
Владимир (4922)49-43-18
Волгоград (844)278-03-48
Вологда (8172)26-41-59
Воронеж (473)204-51-73
Екатеринбург (343)384-55-89
Иваново (4932)77-34-06
Ижевск (3412)26-03-58
Иркутск (395)279-98-46
Казань (843)206-01-48

Калининград (4012)72-03-81
Калуга (4842)92-23-67
Кемерово (3842)65-04-62
Киров (8332)68-02-04
Коломна (4966)23-41-49
Кострома (4942)77-07-48
Краснодар (861)203-40-90
Красноярск (391)204-63-61
Курск (4712)77-13-04
Курган (3522)50-90-47
Липецк (4742)52-20-81
Магнитогорск (3519)55-03-13
Москва (495)268-04-70
Мурманск (8152)59-64-93
Набережные Челны (8552)20-53-41
Нижний Новгород (831)429-08-12
Новокузнецк (3843)20-46-81
Ноябрьск (3496)41-32-12
Новосибирск (383)227-86-73

Омск (3812)21-46-40
Орел (4862)44-53-42
Оренбург (3532)37-68-04
Пенза (8412)22-31-16
Петрозаводск (8142)55-98-37
Псков (8112)59-10-37
Пермь (342)205-81-47
Ростов-на-Дону (863)308-18-15
Рязань (4912)46-61-64
Самара (846)206-03-16
Саранск (8342)22-96-24
Санкт-Петербург (812)-309-46-40
Саратов (845)249-38-78
Севастополь (8692)22-31-93
Симферополь (3652)67-13-56
Смоленск (4812)29-41-54
Сочи (862)225-72-31
Ставрополь (8652)20-65-13
Сургут (3462)77-98-35

Сыктывкар (8212)25-95-17
Тамбов (4752)50-40-97
Тверь (4822)63-31-35
Тольятти (8482)63-91-07
Томск (3822)98-41-53
Тула (4872)33-79-87
Тюмень (3452)66-21-18
Ульяновск (8422)24-23-59
Улан-Удэ (3012)59-97-51
Уфа (347)229-48-12
Хабаровск (4212)92-98-04
Чебоксары (8352)28-53-07
Челябинск (351)202-03-61
Череповец (8202)49-02-64
Чита (3022)38-34-83
Якутск (4112)23-90-97
Ярославль (4852)69-52-93

Россия +7(495)268-04-70

Казахстан +7(7172)727-132

Киргизия +996(312)96-26-47

Эл. почта: sao@nt-rt.ru || Сайт: <https://laser.nt-rt.ru>

Silicon Avalanche Photodiode SAR-/SARP-Series

Description

The SAR500-Series is based on a "reach-through" structure for excellent quantum efficiency and high speed. The peak sensitivity in the NIR region enables rangefinding applications with pulsed laser diodes. A variety of package options is available.

The SARP500-Series is an optimized version of the SAR500 with extremely low noise and dark current and is suitable for detection of very low light levels. The SARP500 is also available in a hermetically sealed TO-37 with thermoelectrical cooler. This enables the APD to be used in a variety of demanding applications including spectroscopy, fluorescence detection, LIDAR and medical applications.

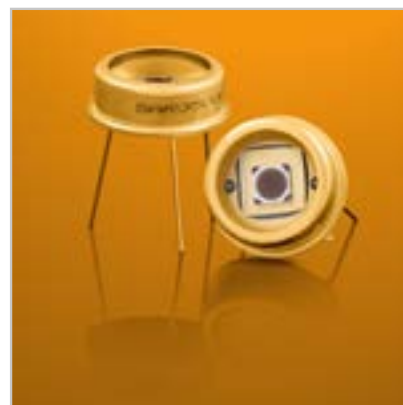

Features

- Very high quantum efficiency
- Low noise, high speed
- Multiplication gain, $M > 200$ available
- 500 μm diameter active area
- Gradual multiplication curve
- Wide operating temperature range
- Fiber-coupled versions available



Applications

- Rangefinding /LIDAR
- Optical communication systems
- Laser scanners
- Spectroscopy
- Fluorescence
- Medical

Generic Characteristics at $T_a = 25\text{ °C}$

	SAR500X/SARP500X			Units
	Min	Typ	Max	
Wavelength range	400		1100	nm
Peak sensitivity		890		nm
Diameter		500		μm

Absolute Maximum Ratings

	SAR500X/SARP500X		Units
	Min	Max	
Storage temperature	-55	100	$^{\circ}\text{C}$
Operating temperature*	-40	85	$^{\circ}\text{C}$
Reverse current Peak value (CW operation)		200	μA
Reverse current Peak value (1 sec duration)		1	mA
Forward current I_f at 25 $^{\circ}\text{C}$, average value (CW operation)		5	mA
Forward current I_f at 25 $^{\circ}\text{C}$, peak value (1 sec duration)		50	mA
Max. total power dissipation		60	mW
Soldering (for 15 sec.)		260	$^{\circ}\text{C}$

* Extended operating temperature range possible for special design considerations

Electrical Characteristics $T_a = 25\text{ }^\circ\text{C}$, $M = 100$

	SAR500X			SARP500X			Units
	Min	Typ	Max	Min	Typ	Max	
Breakdown voltage @ $I_d = 10\text{ }\mu\text{A}$	150	230	400	150	230	400	Volt
Responsivity @ 905 nm		50			50		A/W
V_{br} Temperature coefficient		1	2		1	2	V/ $^\circ\text{C}$
Dark current		1.5	3		0.5	1	nA
Noise current		0.4	1		0.1	0.2	pA/sqrtHz
Capacitance		1.5	3		1.5	3	pF
Rise time		450			450		psec

Fig. 1: Spectral Response @ $M = 100$

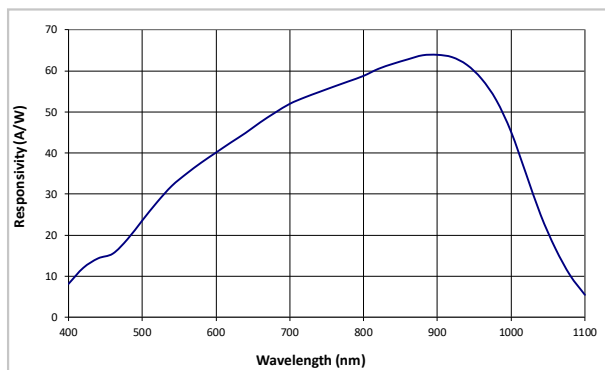

Fig. 2: Quantum Efficiency vs. Wavelength

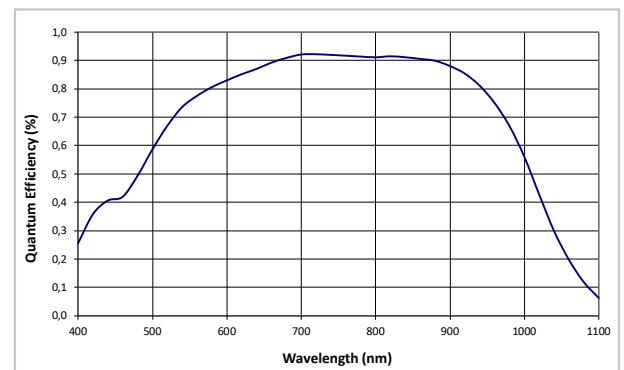

Fig. 3: Typical Dark Current Characteristics

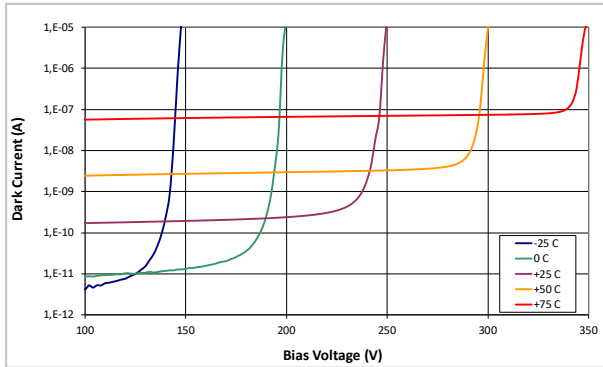

Fig. 4: Gain - Voltage Characteristics @ 905 nm

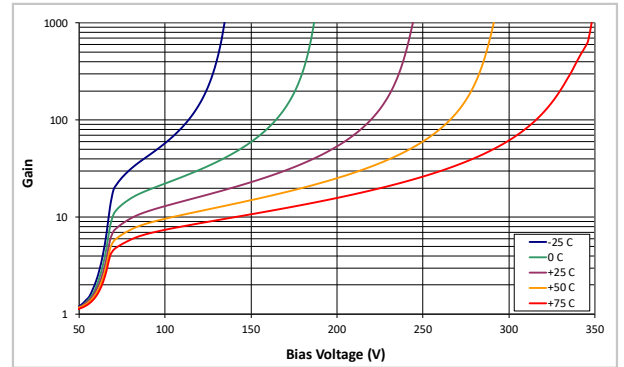

Fig. 5: Capacitance vs. Reverse Voltage

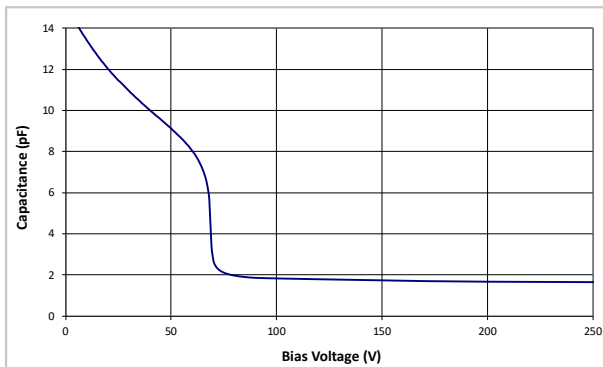

Fig. 6: Typical APD Noise Density as a Function of Gain

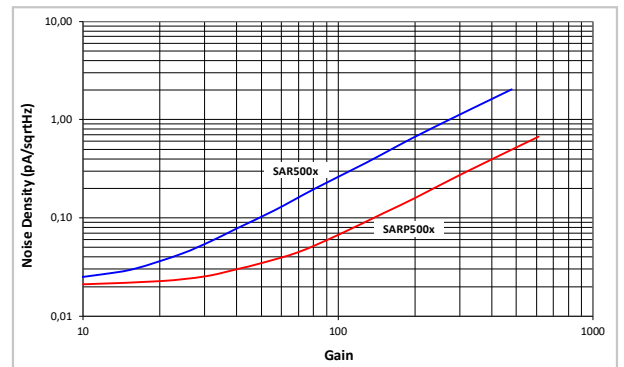

Fig. 7: Excess Noise Factor

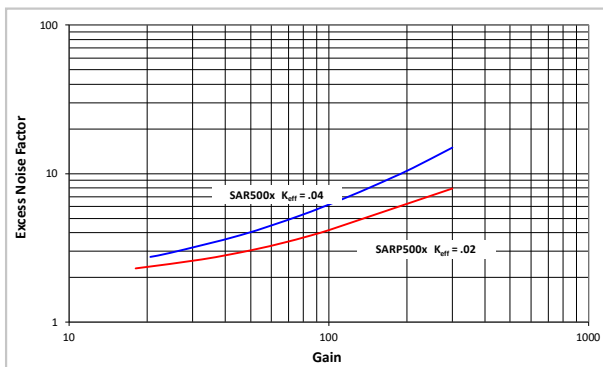
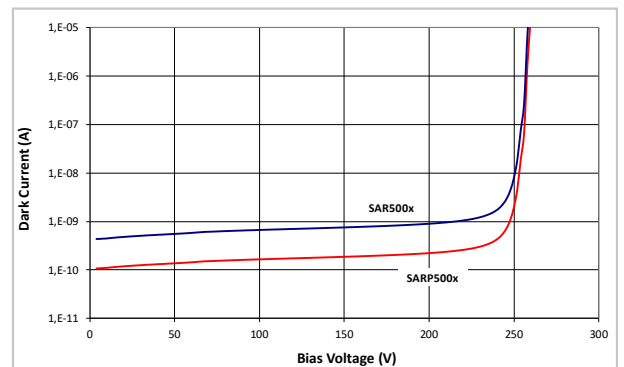
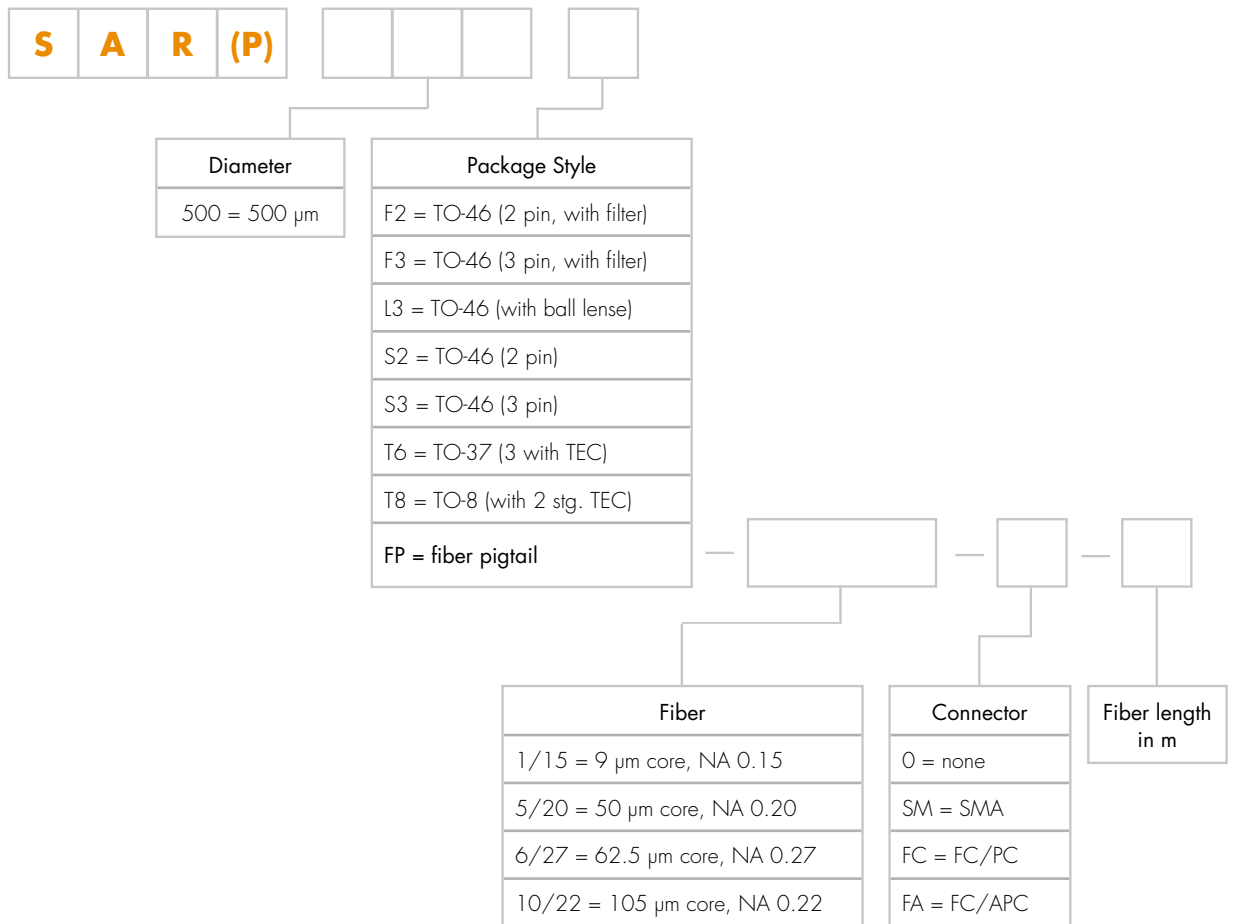

Fig. 8: Dark Current vs. Bias Voltage



Product Number Designations



Note: other fibers and connectors are available on request.

Package Drawings

Package F2 TO-46 (2 pin, with filter)

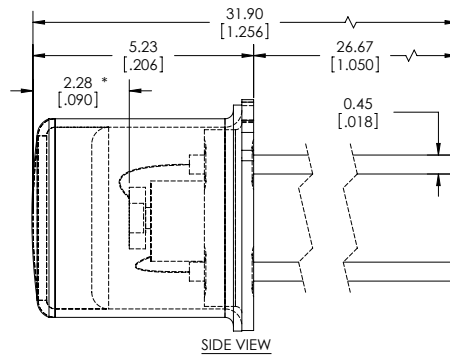

* DISTANCE FROM TOP OF
DEVICE TO TOP OF DETECTOR

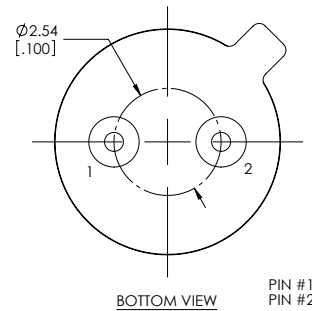
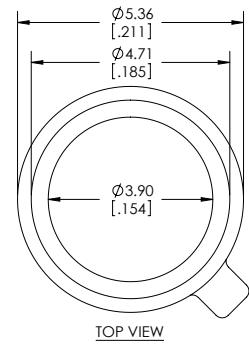

PIN #1: Cathode
PIN #2: Anode

Package F3 TO-46 (3 pin, with filter)

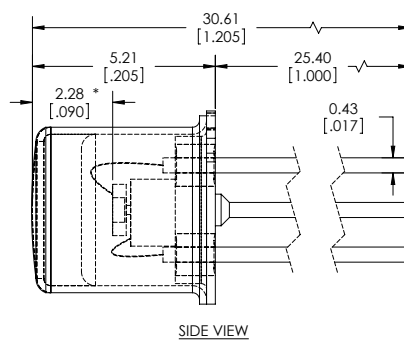

* DISTANCE FROM TOP OF
DEVICE TO TOP OF DETECTOR

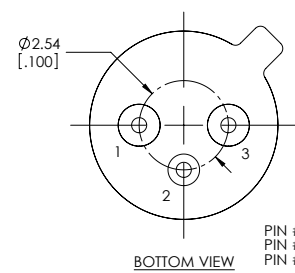
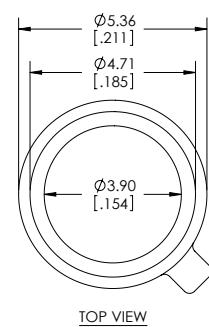

PIN #1: Cathode
PIN #2: Ground/Case
PIN #3: Anode

Package Drawings

Package L3 TO-46 (with ball lens)

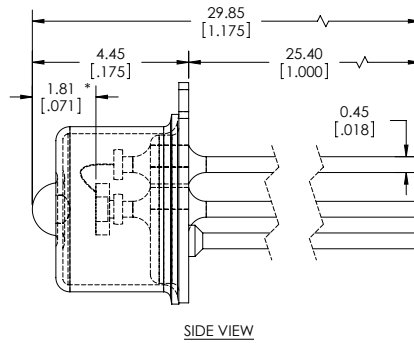

* DISTANCE FROM TOP OF DEVICE TO TOP OF DETECTOR

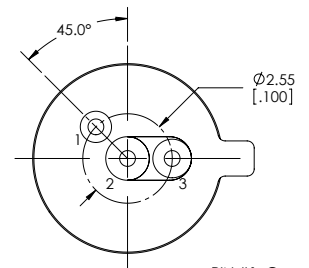
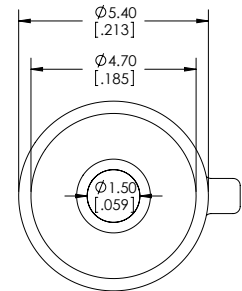

PIN #1: Ground/Case
PIN #2: Cathode
PIN #3: Anode

Package S2 TO-46 (2 pin)

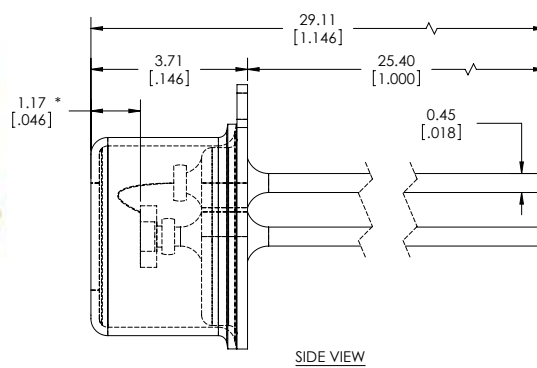

* DISTANCE FROM TOP OF DEVICE TO TOP OF DETECTOR

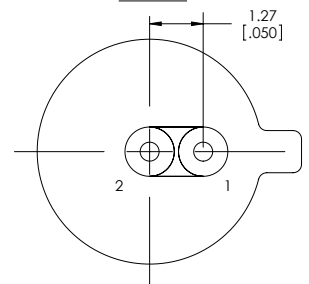
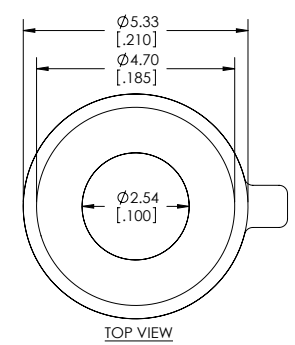

PIN #1: Anode
PIN #2: Cathode

Package Drawings

Package S3 TO-46 (3 pin)

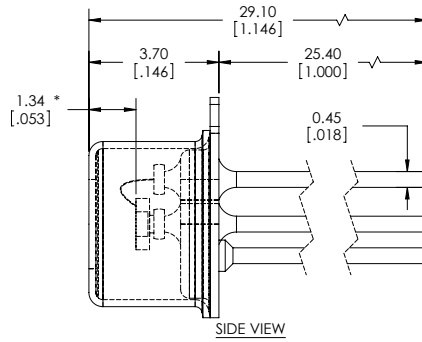

* DISTANCE FROM TOP OF
DEVICE TO TOP OF DETECTOR

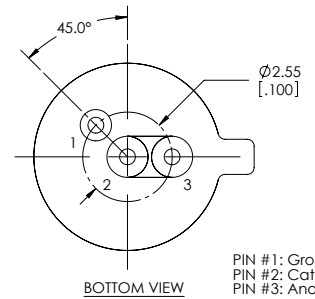
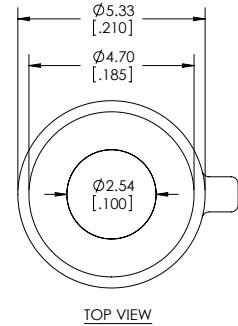

PIN #1: Ground/Case
PIN #2: Cathode
PIN #3: Anode

Package T6 TO-37 (with TEC)

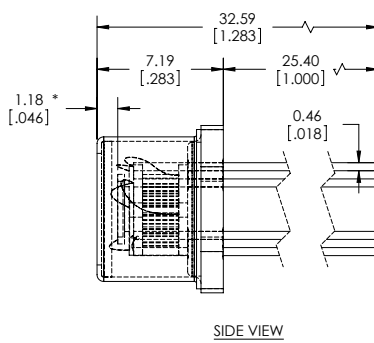

* DISTANCE FROM TOP OF
DEVICE TO TOP OF DETECTOR

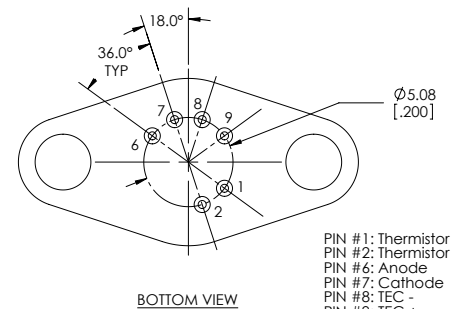
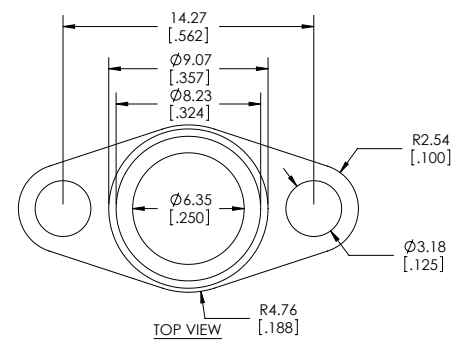

PIN #1: Thermistor
PIN #2: Thermistor
PIN #6: Anode
PIN #7: Cathode
PIN #8: TEC -
PIN #9: TEC +

Package Drawings

Package T8 TO-8 (with 2 stg. TEC)

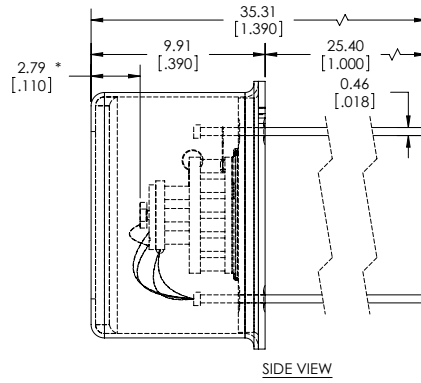

* DISTANCE FROM TOP OF DEVICE TO TOP OF DETECTOR

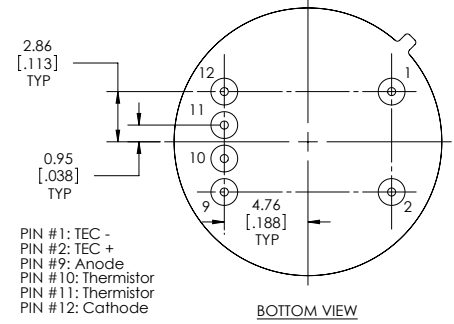
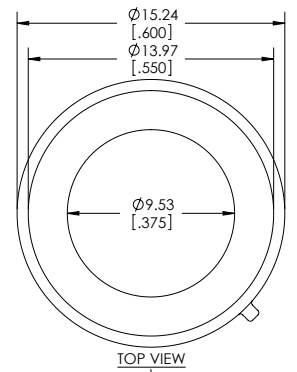

PIN #1: TEC -
PIN #2: TEC +
PIN #9: Anode
PIN #10: Thermistor
PIN #11: Thermistor
PIN #12: Cathode

Package FP Fiber Pigtail

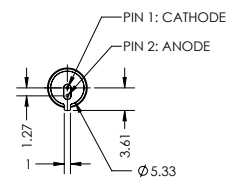
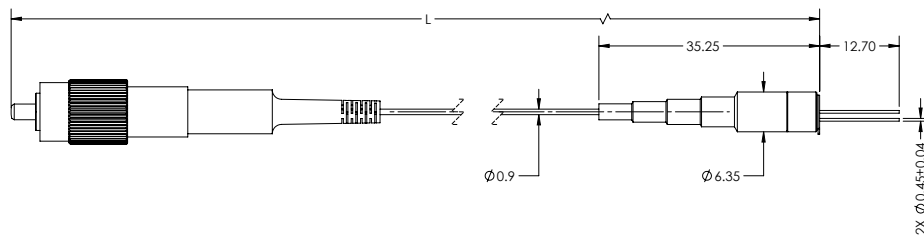

Product Changes

LASER COMPONENTS reserves the right to make changes to the product(s) or information contained herein without notice. No liability is assumed as a result of their use or application.

Ordering Information

Products can be ordered directly from LASER COMPONENTS or its representatives. For a complete listing of representatives, visit our website a

Custom designed products are available on request.

По вопросам продаж и продукции обращайтесь:

Алматы (7273)495-231
Ангарск (3955)60-70-56
Архангельск (8182)63-90-72
Астрахань (8512)99-46-04
Барнаул (3852)73-04-60
Белгород (4722)40-23-64
Благовещенск (4162)22-76-07
Брянск (4832)59-03-52
Владивосток (423)249-28-31
Владикавказ (8672)28-90-48
Владимир (4922)49-43-18
Волгоград (844)278-03-48
Вологда (8172)26-41-59
Воронеж (473)204-51-73
Екатеринбург (343)384-55-89
Иваново (4932)77-34-06
Ижевск (3412)26-03-58
Иркутск (395)279-98-46
Казань (843)206-01-48

Калининград (4012)72-03-81
Калуга (4842)92-23-67
Кемерово (3842)65-04-62
Киров (8332)68-02-04
Коломна (4966)23-41-49
Кострома (4942)77-07-48
Краснодар (861)203-40-90
Красноярск (391)204-63-61
Курск (4712)77-13-04
Курган (3522)50-90-47
Липецк (4742)52-20-81
Магнитогорск (3519)55-03-13
Москва (495)268-04-70
Мурманск (8152)59-64-93
Набережные Челны (8552)20-53-41
Нижний Новгород (831)429-08-12
Новокузнецк (3843)20-46-81
Ноябрьск (3496)41-32-12
Новосибирск (383)227-86-73

Омск (3812)21-46-40
Орел (4862)44-53-42
Оренбург (3532)37-68-04
Пенза (8412)22-31-16
Петрозаводск (8142)55-98-37
Псков (8112)59-10-37
Пермь (342)205-81-47
Ростов-на-Дону (863)308-18-15
Рязань (4912)46-61-64
Самара (846)206-03-16
Саранск (8342)22-96-24
Санкт-Петербург (812)-309-46-40
Саратов (845)249-38-78
Севастополь (8692)22-31-93
Симферополь (3652)67-13-56
Смоленск (4812)29-41-54
Сочи (862)225-72-31
Ставрополь (8652)20-65-13
Сургут (3462)77-98-35

Сыктывкар (8212)25-95-17
Тамбов (4752)50-40-97
Тверь (4822)63-31-35
Тольятти (8482)63-91-07
Томск (3822)98-41-53
Тула (4872)33-79-87
Тюмень (3452)66-21-18
Ульяновск (8422)24-23-59
Улан-Удэ (3012)59-97-51
Уфа (347)229-48-12
Хабаровск (4212)92-98-04
Чебоксары (8352)28-53-07
Челябинск (351)202-03-61
Череповец (8202)49-02-64
Чита (3022)38-34-83
Якутск (4112)23-90-97
Ярославль (4852)69-52-93

Россия +7(495)268-04-70

Казахстан +7(7172)727-132

Киргизия +996(312)96-26-47

Эл. почта: sao@nt-rt.ru || Сайт: <https://laser.nt-rt.ru>