

Алматы (7273)495-231
Ангарск (3955)60-70-56
Архангельск (8182)63-90-72
Астрахань (8512)99-46-04
Барнаул (3852)73-04-60
Белгород (4722)40-23-64
Благовещенск (4162)22-76-07
Брянск (4832)59-03-52
Владивосток (423)249-28-31
Владикавказ (8672)28-90-48
Владимир (4922)49-43-18
Волгоград (844)278-03-48
Вологда (8172)26-41-59
Воронеж (473)204-51-73
Екатеринбург (343)384-55-89
Иваново (4932)77-34-06
Ижевск (3412)26-03-58
Иркутск (395)279-98-46
Казань (843)206-01-48

Калининград (4012)72-03-81
Калуга (4842)92-23-67
Кемерово (3842)65-04-62
Киров (8332)68-02-04
Коломна (4966)23-41-49
Кострома (4942)77-07-48
Краснодар (861)203-40-90
Красноярск (391)204-63-61
Курск (4712)77-13-04
Курган (3522)50-90-47
Липецк (4742)52-20-81
Магнитогорск (3519)55-03-13
Москва (495)268-04-70
Мурманск (8152)59-64-93
Набережные Челны (8552)20-53-41
Нижний Новгород (831)429-08-12
Новокузнецк (3843)20-46-81
Ноябрьск (3496)41-32-12
Новосибирск (383)227-86-73

Омск (3812)21-46-40
Орел (4862)44-53-42
Оренбург (3532)37-68-04
Пенза (8412)22-31-16
Петрозаводск (8142)55-98-37
Псков (8112)59-10-37
Пермь (342)205-81-47
Ростов-на-Дону (863)308-18-15
Рязань (4912)46-61-64
Самара (846)206-03-16
Саранск (8342)22-96-24
Санкт-Петербург (812)-309-46-40
Саратов (845)249-38-78
Севастополь (8692)22-31-93
Симферополь (3652)67-13-56
Смоленск (4812)29-41-54
Сочи (862)225-72-31
Ставрополь (8652)20-65-13
Сургут (3462)77-98-35

Сыктывкар (8212)25-95-17
Тамбов (4752)50-40-97
Тверь (4822)63-31-35
Тольятти (8482)63-91-07
Томск (3822)98-41-53
Тула (4872)33-79-87
Тюмень (3452)66-21-18
Ульяновск (8422)24-23-59
Улан-Удэ (3012)59-97-51
Уфа (347)229-48-12
Хабаровск (4212)92-98-04
Чебоксары (8352)28-53-07
Челябинск (351)202-03-61
Череповец (8202)49-02-64
Чита (3022)38-34-83
Якутск (4112)23-90-97
Ярославль (4852)69-52-93

Россия +7(495)268-04-70

Казахстан +7(7172)727-132

Киргизия +996(312)96-26-47

Эл. почта: sao@nt-rt.ru || Сайт: <https://laser.nt-rt.ru>

L11/21 Series Single Channel Current Mode Pyroelectric Detectors

Description

Our L11/21 series of pyroelectric detectors are a collection of single channel LiTaO_3 devices operating in current mode with an integrated Op-Amp.

TFC (Temperature Fluxuation Compensation) is incorporated into all of our L21- series detectors via the use of an optically blind element.

Features

- Thermal based detector, any radiation absorbed produces a signal
- Wide spectral coverage from the UV to LWIR
- Modular design principle
- Microphonics reduction as standard
- Assembled in an ISO:9001 certified facility

Applications

- Non-dispersive infrared gas analysis
- Flame and fire detection
- Non-contact temperature measurement
- Flame control
- Moisture monitoring

Versions

- Integrated Op-Amp (Split and Single Supply)
- Low and high speed devices available
- Wide range of window and filter options (including small and large apertures)
- A large aperture cap with $5 \times 5 \text{ mm}^2$ is available for applications such as flame detection that requires a wide field of view (FOV). For applications where a smaller aperture is sufficient, example to keep stray light out in gas sensing, a $3.5 \times 3.5 \text{ mm}^2$ aperture is available.

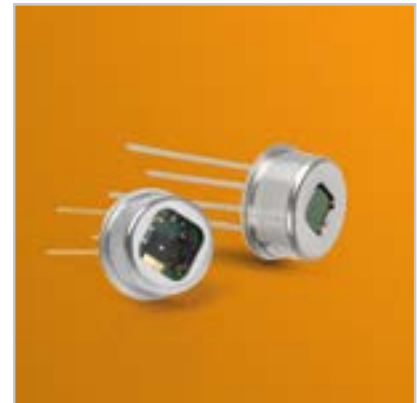

L1100D2020

- Single channel Pyroelectric detector
- Current mode
- Single supply
- Without TFC

Isometric Drawing (with cutaway)

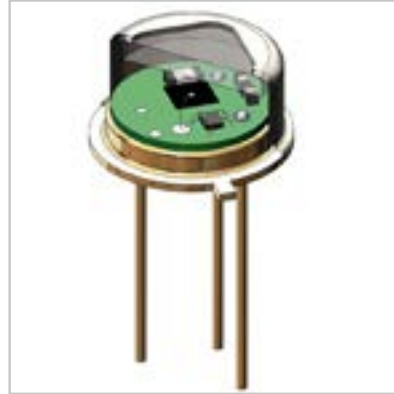

Circuit Diagram

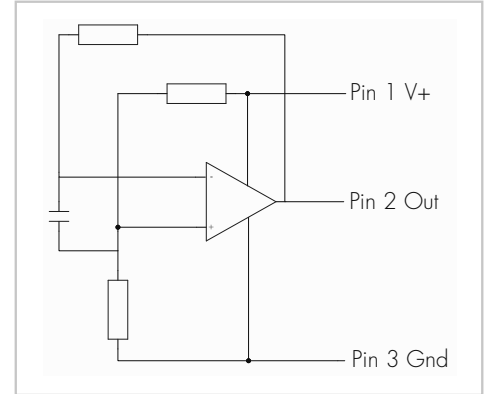

Technical Drawing

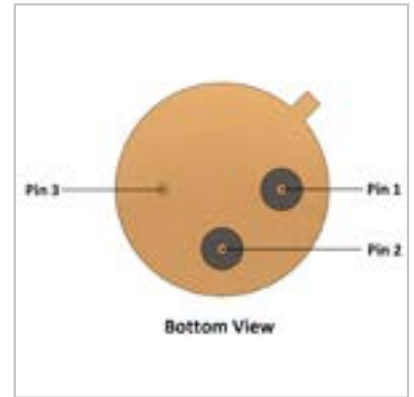
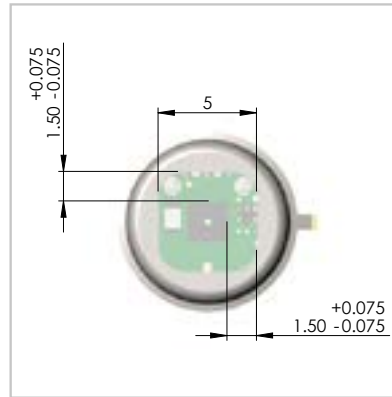
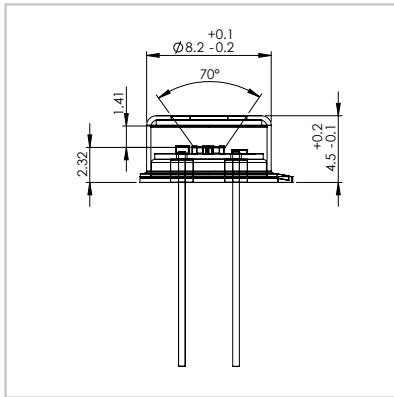

Element Size	Aperture Size*	Package	Absorber
2 mm x 2 mm	5.0 mm Sq. 3.5 mm Sq.	TO-39 3-pin	Organic Black
Feedback Resistor	Amplifier	-3dB Freq [Hz]	Supply Voltage [V]
27 GOhm	Op-Amp 7	TBD	1.8 – 5.5 V (3 V recommended)
Responsivity ** [V/W]	D* (Jones) ** @ 10 Hz	Noise Density [μ V/sqrt(Hz)]	Output Polarity
Min: 30,000 Typ: 40,000	Min: 3×10^8 Typ: 4×10^8	Max: 30	Negative

* Please refer "Filters and Windows" datasheet for all available options (aperture size depends on filter/window option chosen)

** Without filter / window

L1120D2020

- Single channel Pyroelectric detector
- Current mode
- Dual supply
- Without TFC
- High speed

Isometric Drawing (with cutaway)



Circuit Diagram

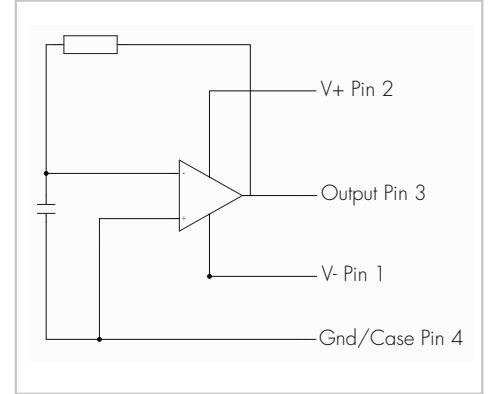

Technical Drawing

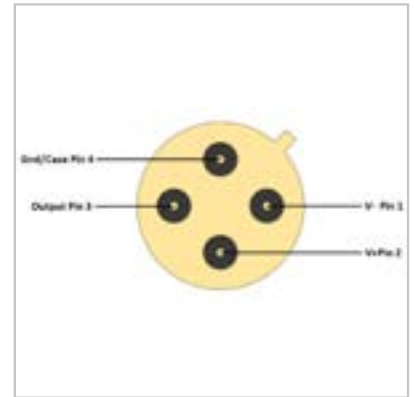
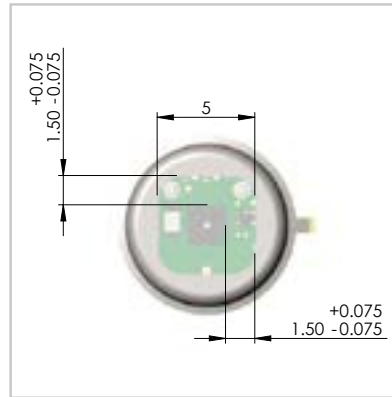
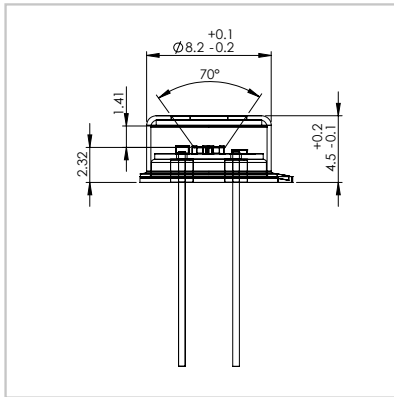

Element Size	Aperture Size*	Package	Absorber
2 mm x 2 mm	5.0 mm Sq. 3.5 mm Sq.	TO-39 4-pin	Organic Black
Feedback Resistor	Amplifier	-3dB Freq [Hz]	Supply Voltage [V]
11 MOhm	Op-Amp 4	TBD	Dual Supply: $\pm 2.5 - \pm 13$ V (V+ = +6 V; V- = -6 V recommended)
Responsivity** [V/W]	D* (Jones)** @ 10 Hz	Noise Density [μ V/sqrt(Hz)]	Output Polarity
Min: 17 Typ: 22	Min: 6.8×10^6 Typ: 1×10^7	Max: 0.5	Negative

* Please refer "Filters and Windows" datasheet for all available options (aperture size depends on filter/window option chosen)

** Without filter / window

L1130D2020

- Single channel Pyroelectric detector
- Current mode
- Single supply
- Without TFC

Isometric Drawing

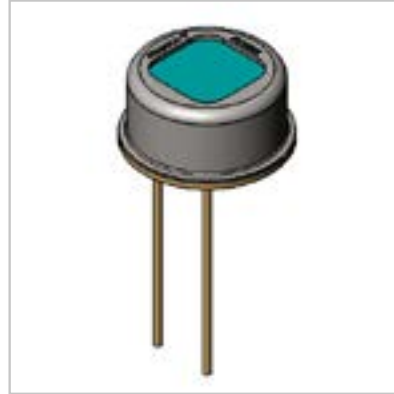

Circuit Diagram

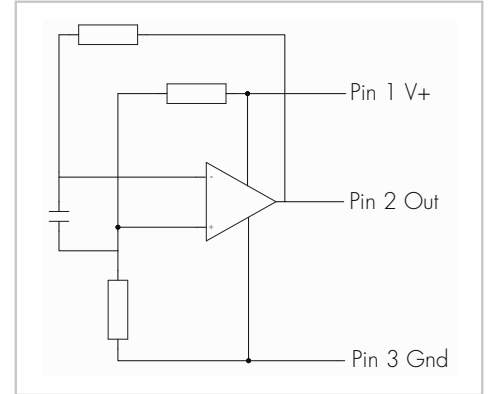

Technical Drawing

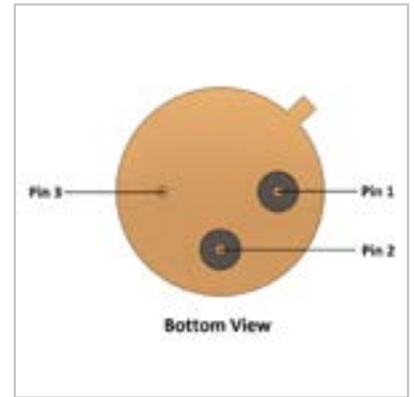
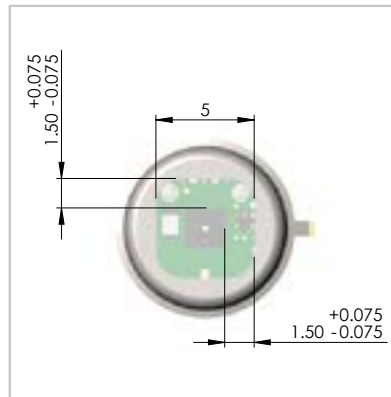
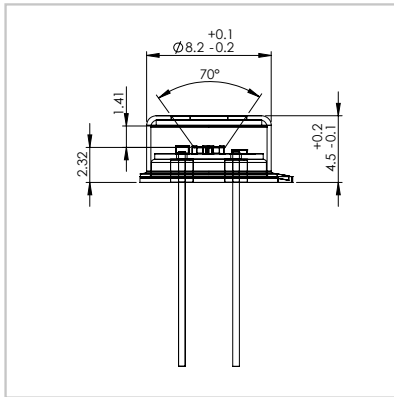

Element Size	Aperture Size*	Package	Absorber
2 mm x 2 mm	5.0 mm Sq. 3.5 mm Sq.	TO-39 3-pin	Organic Black
Feedback Resistor	Amplifier	-3dB Freq [Hz]	Supply Voltage [V]
5 GOhm	Op-Amp 7	TBD	1.8 – 5.5 V (3 V recommended)
Responsivity** [V/W]	D* (Jones)** @ 10 Hz	Noise Density [$\mu\text{V}/\sqrt{\text{Hz}}$]	Output Polarity
Min: 6500 Typ: 7500	Min: 1.5×10^8 Typ: 2.5×10^8	Max: 12	Negative

* Please refer "Filters and Windows" datasheet for all available options (aperture size depends on filter/window option chosen)

** Without filter / window

L2100D2020

- Single channel Pyroelectric detector
- Current mode
- Single supply
- With TFC

Isometric Drawing (with cutaway)



Circuit Diagram

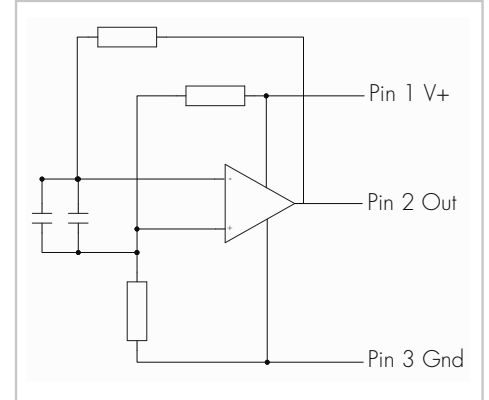

Technical Drawing

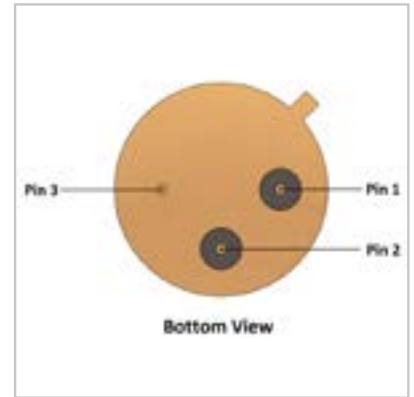
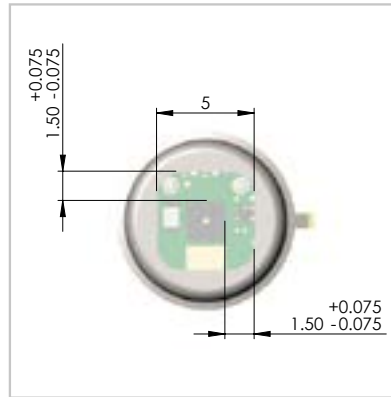
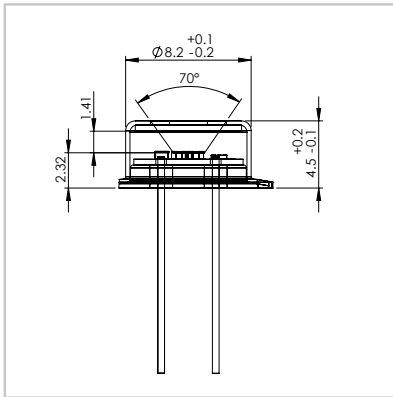

Element Size	Aperture Size*	Package	Absorber
2 mm x 2 mm	5.0 mm Sq. 3.5 mm Sq.	TO-39 3-pin	Organic Black
Feedback Resistor	Amplifier	-3dB Freq [Hz]	Supply Voltage [V]
100 GOhm	Op-Amp 7	TBD	1.8 – 5.5 V (3 V recommended)
Responsivity** [V/W]	D* (Jones)** @ 10 Hz	Noise Density [μV/sqrt(Hz)]	Output Polarity
Min: 100,000 Typ: 150,000	Min: 4.5 x 10 ⁸ Typ: 6 x 10 ⁸	Max: 60	Negative

* Please refer "Filters and Windows" datasheet for all available options
(aperture size depends on filter/window option chosen)

** Without filter / window

L2101D2020

- Single channel Pyroelectric detector
- Current mode
- Single supply
- With TFC
- Optimized for low frequency applications (~5 Hz)

Isometric Drawing (with cutaway)



Circuit Diagram

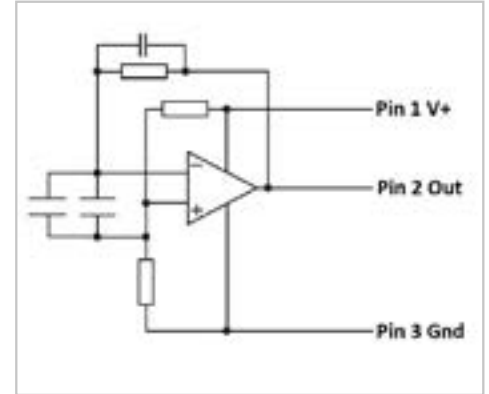

Technical Drawing

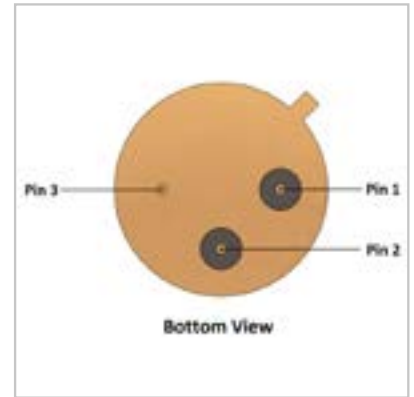
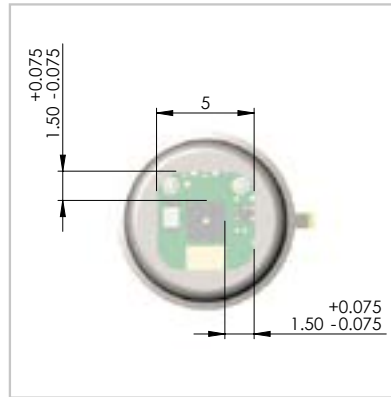
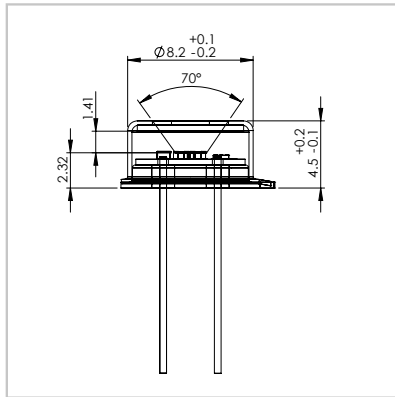

Element Size	Aperture Size*	Package	Absorber
2 mm x 2 mm	5.0 mm Sq. 3.5 mm Sq.	TO-39 3-pin	Organic Black
Feedback Resistor	Amplifier	-3dB Freq [Hz]	Supply Voltage [V]
100 GOhm	Op-Amp 7	TBD	2.7 – 10 V (3 V recommended)
Responsivity** [V/W]	D* (Jones)** @ 5 Hz	Noise Density [$\mu\text{V}/\sqrt{\text{Hz}}$]	Output Polarity
Min: 40,000 Typ: 45,000	Min: 7.5×10^8 Typ: 9.0×10^8	Max: 14	Negative

* Please refer "Filters and Windows" datasheet for all available options (aperture size depends on filter/window option chosen)

** Without filter / window

Absolute Maximum Ratings

	Min	Max
Storage temperature [°C]	- 25	+ 60 **
Operating temperature [°C]	- 20	+ 85
Soldering temperature, 5 sec [°C]	+ 280	+ 300
ESD damage threshold, Human Body Model Class* [V]	0	< 250

* ANSI/ESD STN5. 1-2007

** Limited by packing materials.

Handling

ESD sensitive device. High electrostatic discharge can damage or degrade the device.

Use proper ESD handling precautions.

Part Number Designation



По вопросам продаж и продукции обращайтесь:

Алматы (7273)495-231
Ангарск (3955)60-70-56
Архангельск (8182)63-90-72
Астрахань (8512)99-46-04
Барнаул (3852)73-04-60
Белгород (4722)40-23-64
Благовещенск (4162)22-76-07
Брянск (4832)59-03-52
Владивосток (423)249-28-31
Владикавказ (8672)28-90-48
Владимир (4922)49-43-18
Волгоград (844)278-03-48
Вологда (8172)26-41-59
Воронеж (473)204-51-73
Екатеринбург (343)384-55-89
Иваново (4932)77-34-06
Ижевск (3412)26-03-58
Иркутск (395)279-98-46
Казань (843)206-01-48

Калининград (4012)72-03-81
Калуга (4842)92-23-67
Кемерово (3842)65-04-62
Киров (8332)68-02-04
Коломна (4966)23-41-49
Кострома (4942)77-07-48
Краснодар (861)203-40-90
Красноярск (391)204-63-61
Курск (4712)77-13-04
Курган (3522)50-90-47
Липецк (4742)52-20-81
Магнитогорск (3519)55-03-13
Москва (495)268-04-70
Мурманск (8152)59-64-93
Набережные Челны (8552)20-53-41
Нижегород (831)429-08-12
Новокузнецк (3843)20-46-81
Ноябрьск (3496)41-32-12
Новосибирск (383)227-86-73

Омск (3812)21-46-40
Орел (4862)44-53-42
Оренбург (3532)37-68-04
Пенза (8412)22-31-16
Петрозаводск (8142)55-98-37
Псков (8112)59-10-37
Пермь (342)205-81-47
Ростов-на-Дону (863)308-18-15
Рязань (4912)46-61-64
Самара (846)206-03-16
Саранск (8342)22-96-24
Санкт-Петербург (812)-309-46-40
Саратов (845)249-38-78
Севастополь (8692)22-31-93
Симферополь (3652)67-13-56
Смоленск (4812)29-41-54
Сочи (862)225-72-31
Ставрополь (8652)20-65-13
Сургут (3462)77-98-35

Сыктывкар (8212)25-95-17
Тамбов (4752)50-40-97
Тверь (4822)63-31-35
Тольятти (8482)63-91-07
Томск (3822)98-41-53
Тула (4872)33-79-87
Тюмень (3452)66-21-18
Ульяновск (8422)24-23-59
Улан-Удэ (3012)59-97-51
Уфа (347)229-48-12
Хабаровск (4212)92-98-04
Чебоксары (8352)28-53-07
Челябинск (351)202-03-61
Череповец (8202)49-02-64
Чита (3022)38-34-83
Якутск (4112)23-90-97
Ярославль (4852)69-52-93